



# Programming Guide EtherNet/IP

VLT® Midi Drive FC 280





## Contents

<b>1 Introduction</b>	<b>2</b>
1.1 Purpose of the Manual	2
1.2 Additional Resources	2
1.3 Document and Software Version	2
1.4 Product Overview	2
1.5 Approvals and Certifications	2
1.6 Symbols, Abbreviations, and Conventions	3
<b>2 Safety</b>	<b>4</b>
2.1 Safety Symbols	4
2.2 Qualified Personnel	4
2.3 Safety Precautions	4
<b>3 Configuration</b>	<b>6</b>
3.1 IP Settings	6
3.2 Ethernet Link Parameters	6
3.3 Configuring the Scanner	7
3.4 IP Traffic	11
<b>4 Control</b>	<b>12</b>
4.1 I/O Assembly Instances	12
4.2 EtherNet/IP Connections	13
4.3 FC Control Profile	15
4.4 ODVA Control Profile	17
4.5 Reference Handling	19
<b>5 Parameters</b>	<b>21</b>
5.1 Parameter Group 8-** Communication and Option	21
5.2 Parameter Group 12-** Ethernet	25
5.3 Parameter List	31
<b>6 Troubleshooting</b>	<b>34</b>
6.1 Step-by-step Troubleshooting	34
6.2 Warnings and Alarms	35
<b>7 Appendix</b>	<b>37</b>
7.1 Supported CIP Objects	37
<b>Index</b>	<b>44</b>

# 1 Introduction

## 1.1 Purpose of the Manual

The *EtherNet/IP Programming Guide* provides information about configuring the system, controlling the frequency converter, accessing parameters, programming, and troubleshooting.

The *programming guide* is intended for use by qualified personnel familiar with the VLT® frequency converter, with EtherNet/IP technology, and with the PC or PLC used as a master in the system.

Read the instructions before programming and follow the procedures in this manual.

VLT® is a registered trademark.

CIP™ is a registered trademark.

EtherNet/IP™ is a trademark of ODVA, Inc.

## 1.2 Additional Resources

Resources available for the frequency converter and optional equipment are:

- The *VLT® Midi Drive FC 280 Operating Guide* provides the necessary information to get the frequency converter up and running.
- The *VLT® Midi Drive FC 280 Design Guide* provides detailed information about capabilities and functionality to design motor control systems.
- The *VLT® Midi Drive FC 280 Programming Guide* provides more details on working with parameters and many application examples.

Supplementary publications and manuals are available from Danfoss. See [drives.danfoss.com/knowledge-center/technical-documentation/](http://drives.danfoss.com/knowledge-center/technical-documentation/) for listings.

## 1.3 Document and Software Version

This manual is regularly reviewed and updated. All suggestions for improvement are welcome. *Table 1.1* shows the document version and the corresponding software version.

Edition	Remarks	Software version
MG07H1xx	The first edition of this manual.	2.17

Table 1.1 Document and Software Version

## 1.4 Product Overview

This *programming guide* relates to the EtherNet/IP interface for VLT® Midi Drive FC 280.

The EtherNet/IP interface is designed to communicate with any system complying with the CIP EtherNet/IP standard. EtherNet/IP provides users with the network tools to deploy standard Ethernet technology for manufacturing applications while enabling internet and enterprise connectivity.

The EtherNet/IP control cassette is intended for use with VLT® Midi Drive FC 280.

## 1.5 Approvals and Certifications

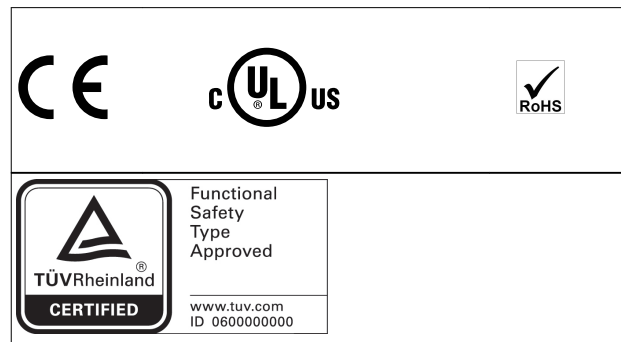

More approvals and certifications are available. For more information, contact a local Danfoss partner.

## 1.6 Symbols, Abbreviations, and Conventions

Abbreviation	Definition
API	Actual packet interval
CC	Control card
CIP™	Common industrial protocol
COS	Change of state
CTW	Control word
DHCP	Dynamic host configuration protocol
EIP	EtherNet/IP
EMC	Electromagnetic compatibility
FC	Frequency converter
I/O	Input/output
IP	Internet protocol
LCP	Local control panel
LED	Light emitting diode
LSB	Least significant bit
MAR	Major recoverable fail
MAU	Major unrecoverable fail
MAV	Main actual value (actual output)
MIR	Minor recoverable fail
MSB	Most significant bit
MRV	Main reference value
N/A	Not applicable
ODVA	Open DeviceNet Vendors Association
PC	Personal computer
PLC	Programmable logic controller
PNU	Parameter number
REF	Reference (= MRV)
RTC	Real-time clock
STP	Spanning tree protocol
STW	Status word

**Table 1.2 Symbols and Abbreviations**

### Conventions

Numbered lists indicate procedures.

Bullet lists indicate other information and description of illustrations.

Italicized text indicates:

- Cross-reference.
- Link.
- Parameter name.
- Parameter group name.
- Parameter option.

All dimensions in drawings are in mm (in).

## 2

## 2 Safety

### 2.1 Safety Symbols

The following symbols are used in this guide:

#### **⚠ WARNING**

Indicates a potentially hazardous situation that could result in death or serious injury.

#### **⚠ CAUTION**

Indicates a potentially hazardous situation that could result in minor or moderate injury. It can also be used to alert against unsafe practices.

#### **NOTICE**

Indicates important information, including situations that can result in damage to equipment or property.

### 2.2 Qualified Personnel

Correct and reliable transport, storage, installation, operation, and maintenance are required for the trouble-free and safe operation of the frequency converter. Only qualified personnel are allowed to install and operate this equipment.

Qualified personnel are defined as trained staff, who are authorized to install, commission, and maintain equipment, systems, and circuits in accordance with pertinent laws and regulations. Also, the qualified personnel must be familiar with the instructions and safety measures described in this manual.

### 2.3 Safety Precautions

#### **⚠ WARNING**

##### **HIGH VOLTAGE**

Frequency converters contain high voltage when connected to AC mains input, DC supply, or load sharing. Failure to perform installation, start-up, and maintenance by qualified personnel can result in death or serious injury.

- Only qualified personnel must perform installation, start-up, and maintenance.

#### **⚠ WARNING**

##### **UNINTENDED START**

When the frequency converter is connected to AC mains, DC supply, or load sharing, the motor may start at any time. Unintended start during programming, service, or repair work can result in death, serious injury, or property damage. The motor can start with an external switch, a fieldbus command, an input reference signal from the LCP or LOP, via remote operation using MCT 10 Set-up Software, or after a cleared fault condition.

To prevent unintended motor start:

- Press [Off/Reset] on the LCP before programming parameters.
- Disconnect the frequency converter from the mains.
- Completely wire and assemble the frequency converter, motor, and any driven equipment before connecting the frequency converter to AC mains, DC supply, or load sharing.

#### **⚠ WARNING**

##### **DISCHARGE TIME**

The frequency converter contains DC-link capacitors, which can remain charged even when the frequency converter is not powered. High voltage can be present even when the warning LED indicator lights are off. Failure to wait the specified time after power has been removed before performing service or repair work can result in death or serious injury.

- Stop the motor.
- Disconnect AC mains and remote DC-link supplies, including battery back-ups, UPS, and DC-link connections to other frequency converters.
- Disconnect or lock PM motor.
- Wait for the capacitors to discharge fully. The minimum waiting time is specified in the *chapter Safety* in the *operating guide* supplied with the frequency converter.
- Before performing any service or repair work, use an appropriate voltage measuring device to make sure that the capacitors are fully discharged.

**⚠ WARNING****LEAKAGE CURRENT HAZARD**

Leakage currents exceed 3.5 mA. Failure to ground the frequency converter properly can result in death or serious injury.

- Ensure the correct grounding of the equipment by a certified electrical installer.

**⚠ WARNING****EQUIPMENT HAZARD**

Contact with rotating shafts and electrical equipment can result in death or serious injury.

- Ensure that only trained and qualified personnel perform installation, start-up, and maintenance.
- Ensure that electrical work conforms to national and local electrical codes.
- Follow the procedures in this guide.

**⚠ CAUTION****INTERNAL FAILURE HAZARD**

An internal failure in the frequency converter can result in serious injury when the frequency converter is not properly closed.

- Ensure that all safety covers are in place and securely fastened before applying power.

## 3 Configuration

## 3

### 3.1 IP Settings

All IP-related parameters are located in *parameter group 12-0\* IP Settings*:

- *Parameter 12-00 IP Address Assignment.*
- *Parameter 12-01 IP Address.*
- *Parameter 12-02 Subnet Mask.*
- *Parameter 12-03 Default Gateway.*
- *Parameter 12-04 DHCP Server.*
- *Parameter 12-05 Lease Expires.*
- *Parameter 12-06 Name Servers.*
- *Parameter 12-07 Domain Name.*
- *Parameter 12-08 Host Name.*
- *Parameter 12-09 Physical Address.*

The EtherNet/IP control cassette offers several ways of IP address assignment.

#### Setting up the frequency converter with a manually assigned IP address

Parameter	Value
<i>Parameter 12-00 IP Address Assignment</i>	[0] MANUAL
<i>Parameter 12-01 IP Address</i>	192.168.0.xxx <sup>1)</sup>
<i>Parameter 12-02 Subnet Mask</i>	255.255.255.0 <sup>1)</sup>
<i>Parameter 12-03 Default Gateway</i>	Optional

Table 3.1 Set-up Parameters for Manually Assigned IP Address

1) Class C IP address example. Any valid IP address can be entered.

#### NOTICE

A power cycle is necessary after setting the IP parameters manually.

#### Setting up the frequency converter with automatically (BOOTP/DHCP) assigned IP address or via the hardware switches

Parameter	Value
<i>Parameter 12-00 IP Address Assignment</i>	[1] DHCP/[2] BOOTP
<i>Parameter 12-01 IP Address</i>	Read only
<i>Parameter 12-02 Subnet Mask</i>	Read only
<i>Parameter 12-03 Default Gateway</i>	Read only

Table 3.2 Set-up Parameters for Automatically Assigned IP Address

By IP address assigned by DHCP/BOOTP server or hardware switches, the assigned IP address and subnet mask can be read out in *parameter 12-01 IP Address* and *parameter 12-02 Subnet Mask*. In *parameter 12-04 DHCP Server*, the IP address of the found DHCP or BOOTP server is shown. For DHCP only: The remaining lease-time can be read out in *parameter 12-05 Lease Expires*.

*Parameter 12-09 Physical Address* reads out the MAC address of the option, which is also printed on the label of the option. If using fixed leases together with DHCP or BOOTP, the physical MAC address is linked with a fixed IP address.

#### NOTICE

If no DHCP or BOOTP reply has been received after 4 attempts (for example, if the DHCP/BOOTP server has been powered off), the option returns to the last good known IP address.

*Parameter 12-03 Default Gateway* is optional and only used in routed networks.

Optional parameters used with domain name server systems:

- *Parameter 12-06 Name Servers.*
- *Parameter 12-06 Name Servers.*
- *Parameter 12-08 Host Name.*

If DHCP or BOOTP is selected as IP address assignment, these parameters are read-only.

### 3.2 Ethernet Link Parameters

*Parameter group 12-1\* Ethernet Link Parameters* holds Ethernet Link information:

- *Parameter 12-10 Link Status.*
- *Parameter 12-11 Link Duration.*
- *Parameter 12-12 Auto Negotiation.*
- *Parameter 12-13 Link Speed.*
- *Parameter 12-14 Link Duplex.*

#### NOTICE

The Ethernet link parameters are unique per port.

*Parameter 12-10 Link Status* and *parameter 12-11 Link Duration* show information on the link status per port. *Parameter 12-10 Link Status* show Link or No Link according to the status of the present port.

*Parameter 12-11 Link Duration* show the duration of the link on the present port. If the link is broken, the counter resets.



*Parameter 12-12 Auto Negotiation* is a feature that enables 2 connected Ethernet devices to select common transmission parameter, such as speed and duplex mode. In this process, the connected devices first share their capabilities for these parameters and then select the fastest transmission mode they both support. By default, this function is enabled. Incapability between the connected devices may lead to decreased communication performance. To prevent decreased performance, auto negotiation can be disabled. If *parameter 12-12 Auto Negotiation* is set to [0] Off, link speed and duplex mode can be configured manually in *parameter 12-13 Link Speed* and *parameter 12-14 Link Duplex*.

*Parameter 12-13 Link Speed* shows/sets the link speed per port. If no link is present, none is shown.

*Parameter 12-14 Link Duplex* shows/sets the duplex mode per port. Half duplex provides communication in both directions, but only in 1 direction at a time (not simultaneously). Full-duplex allows communication in both directions, and unlike half duplex, allows for communication in both directions to happen simultaneously.

### 3.3 Configuring the Scanner

#### EDS file

Danfoss provides an English EDS (electronic datasheet) file covering all voltage and power sizes for off-line configuration.

The EDS file can be downloaded from:  
[drives.danfoss.com/services/software-downloads/](http://drives.danfoss.com/services/software-downloads/).

#### Configuring a Rockwell master

To configure a frequency converter with EtherNet/IP control cassette for operation with a Rockwell (Allen-Bradley) scanner via EtherNet/IP, install the EDS file first.

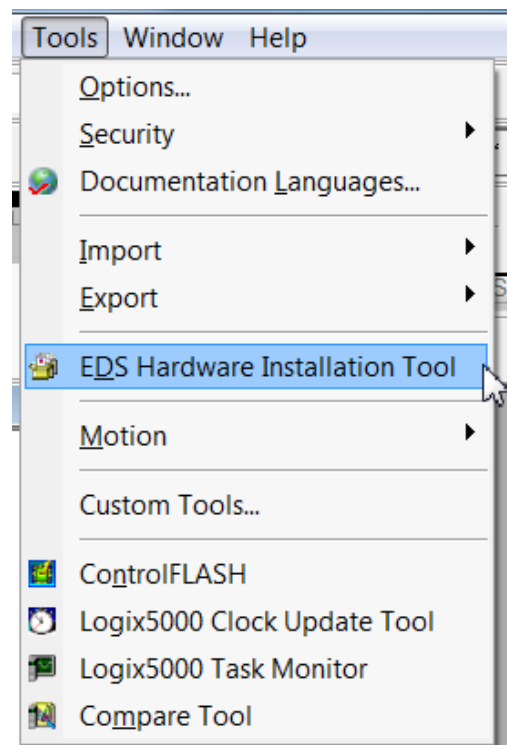

Illustration 3.1 Selecting the Tool Menu and the EDS Hardware Installation Tool Menu

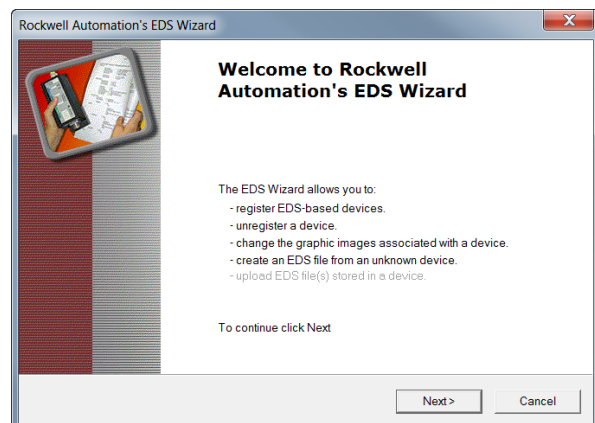

Illustration 3.2 Starting the EDS Wizard Tool

3

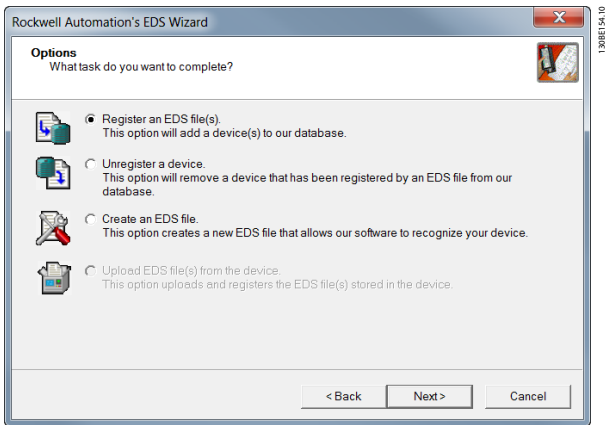

Illustration 3.3 Registering 1 or More EDS Files

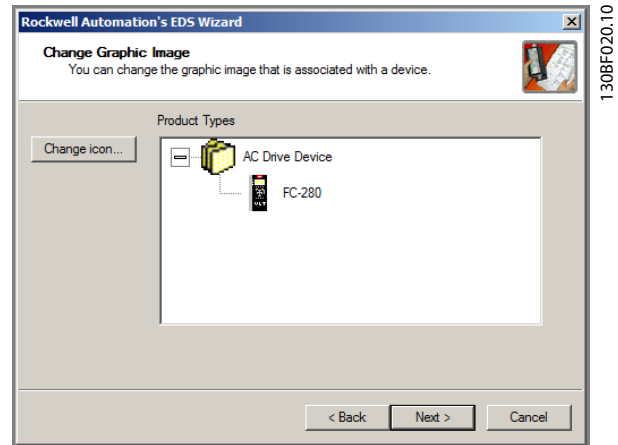

Illustration 3.6 Changing the Graphic Image

The EDS file contains all files. To install the EDS file, install the complete directory.

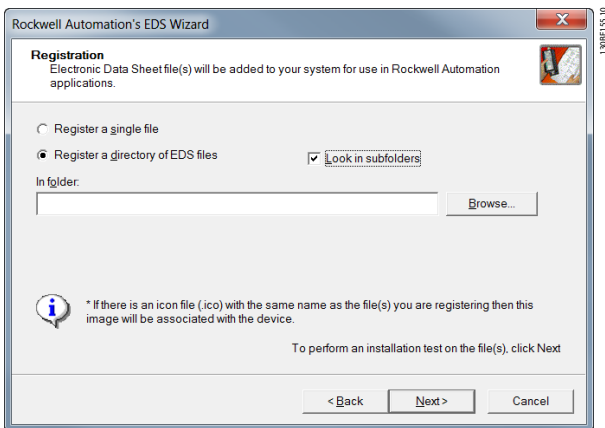

Illustration 3.4 Registering a Directory of EDS Files

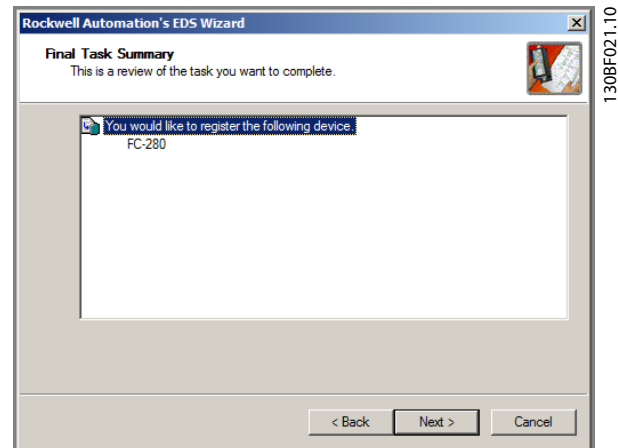

Illustration 3.7 Final Task Summary

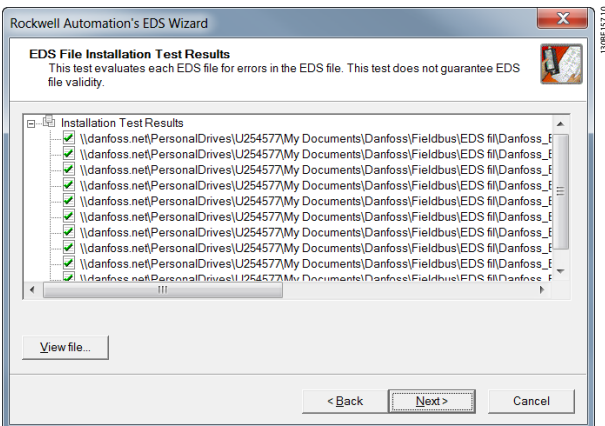

Illustration 3.5 Selecting the Directory Containing the EDS Files

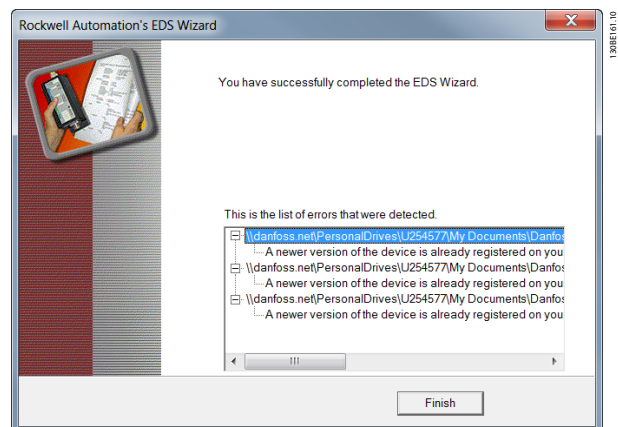

Illustration 3.8 Installed EDS files shown after a Successful Installation

The following example sets up the configuration between a Rockwell scanner and a VLT<sup>®</sup> Midi Drive FC 280, where the I/O assembly 100/150 is used.

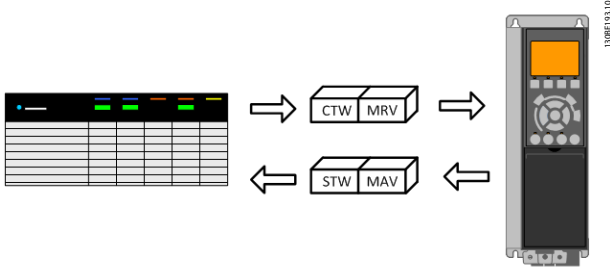

Illustration 3.9 Setting Up the Configuration between a Rockwell Scanner and a VLT<sup>®</sup> Midi Drive FC 280

The scanner sends 2 words. The 1<sup>st</sup> word is the frequency converters control word (CTW), and the 2<sup>nd</sup> word is the main reference value (MRV). The frequency converter sends 2 words to the scanner. The 1<sup>st</sup> word is the status word (STW), and the 2<sup>nd</sup> word is the main actual value (MAV) (actual speed).

The frequency converter has the IP address 192.168.1.121, and the data is updated cyclic every 20 ms in each direction (RPI = 20 ms). To get the best network performance, the data is sent unicast between the scanner and the VLT<sup>®</sup> Midi Drive FC 280.

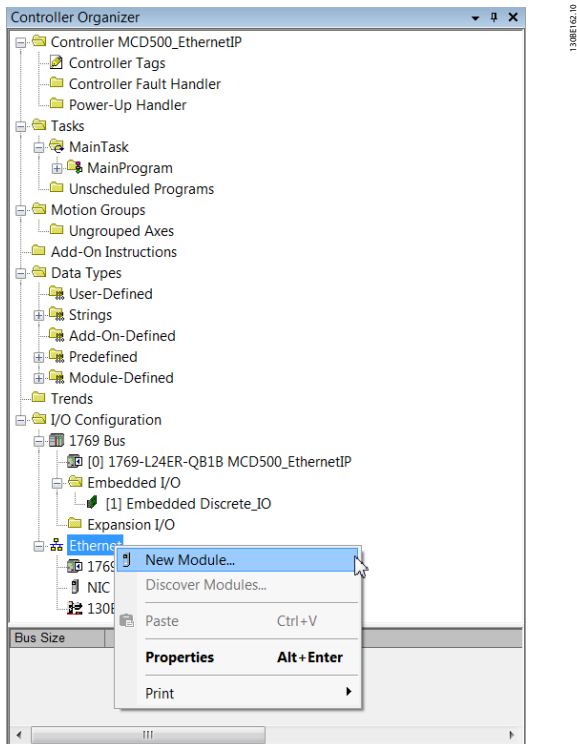

Illustration 3.10 Adding the Danfoss Frequency Converters to the Scanner

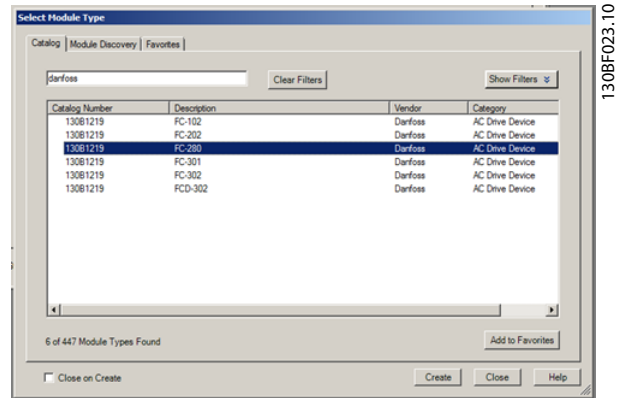

Illustration 3.11 Limiting the Number of Devices in the Catalog View

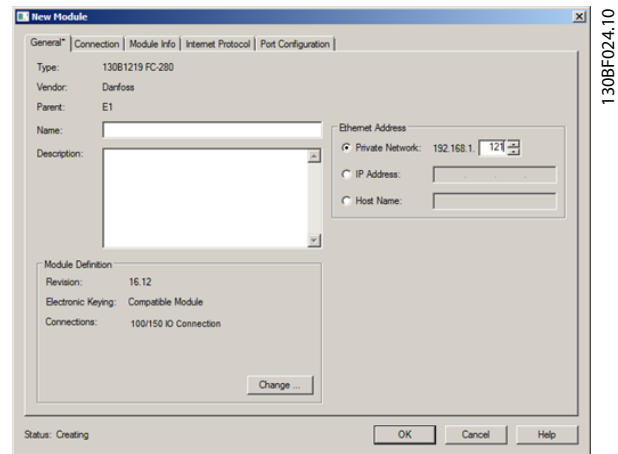

Illustration 3.12 Naming the Frequency Converter and Assigning the IP Address

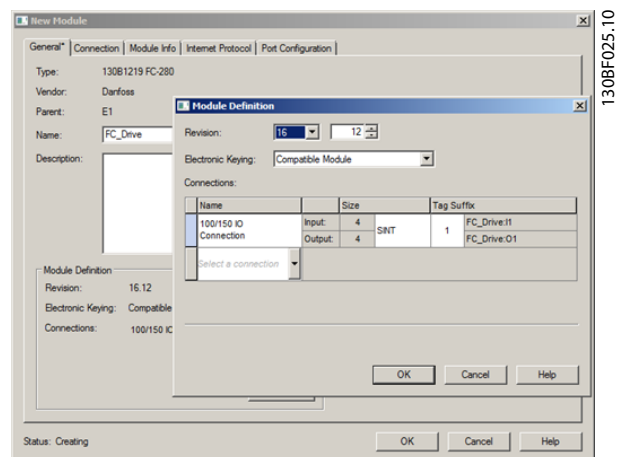

Illustration 3.13 Selecting the Change Option in the Module Definition Part

3

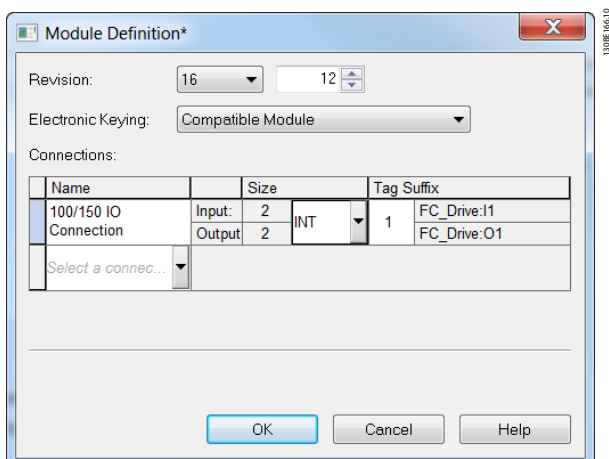

Illustration 3.14 Changing the Settings

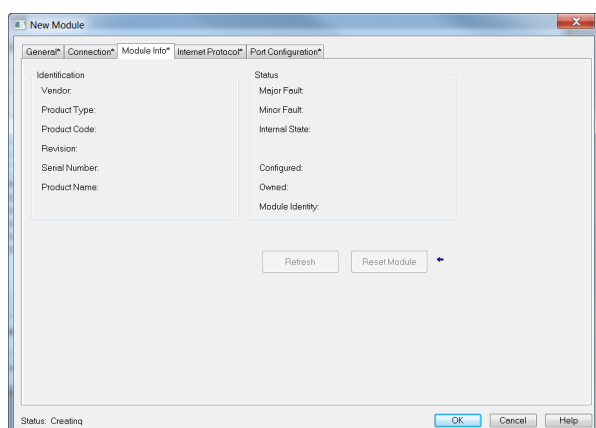

Illustration 3.17 Actual Values of the Frequency Converter

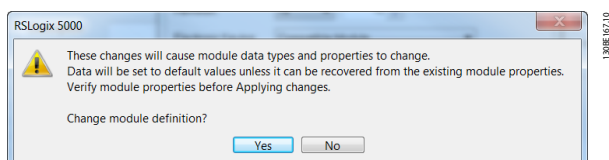

Illustration 3.15 Changing the Connection Properties

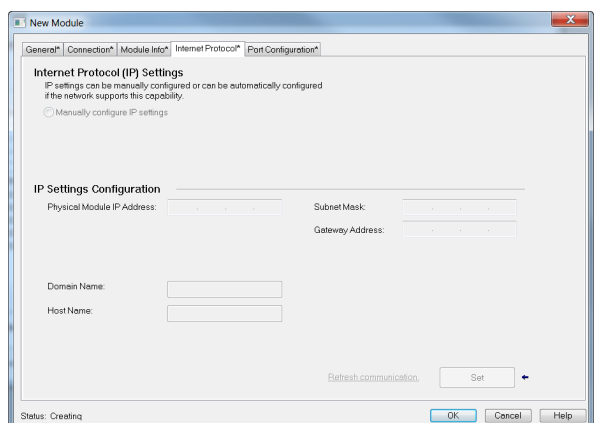

Illustration 3.18 Online IP Address Settings of the Frequency Converter

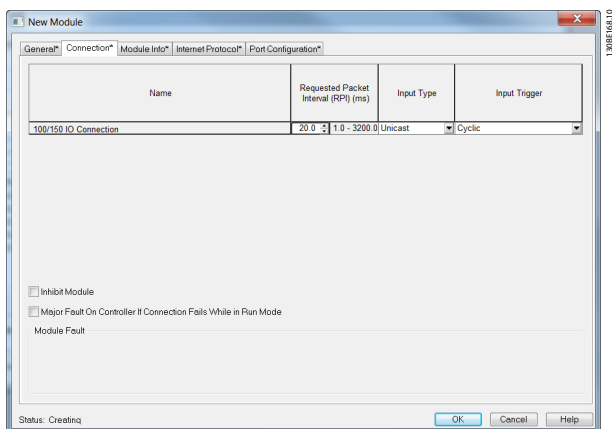

Illustration 3.16 Setting the RPI, Input Type, and Input Trigger

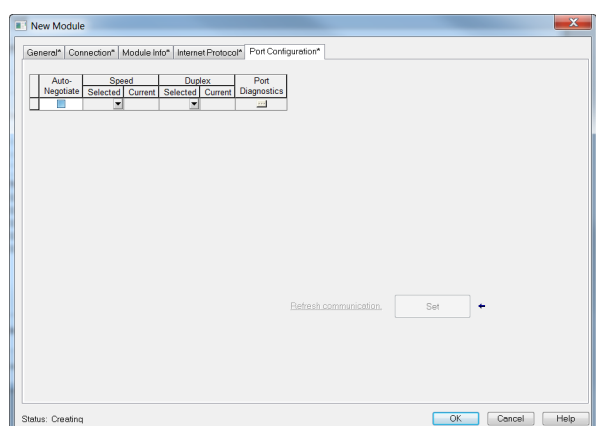

Illustration 3.19 Online Port Configuration of the Frequency Converter

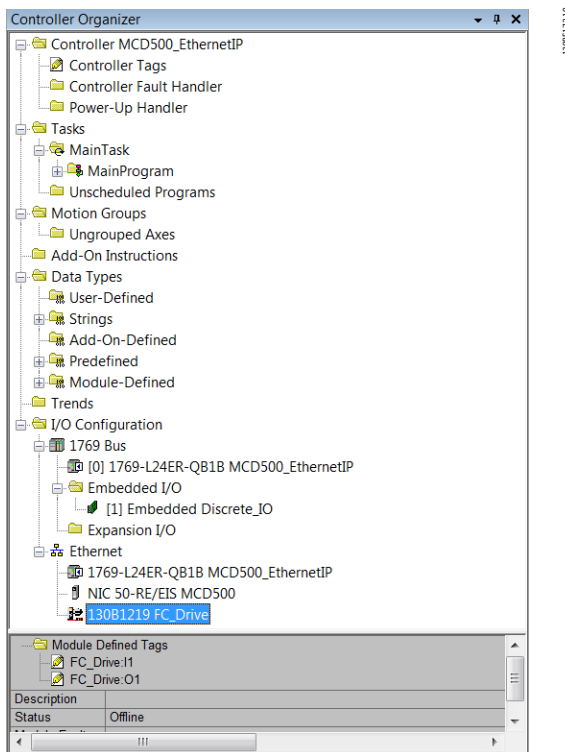

Illustration 3.20 The Frequency Converter Successfully Created in the Hardware Configuration

Name	Value	Force Mask	Style	Data Type	Description
- FC_Drive11	{...}	{...}		_0061:130B121...	
FC_Drive11.ConnectionFaulted	0		Decimal	BOOL	
- FC_Drive11 Data	{...}	{...}			
+ FC_Drive11 Data[0]	0		Decimal	INT[2]	Status Word
+ FC_Drive11 Data[1]	0		Decimal	INT	Main Actual Value
- FC_Drive01	{...}	{...}		_0061:130B121...	
- FC_Drive01 Data	{...}	{...}			
+ FC_Drive01 Data[0]	0		Decimal	INT[2]	Control Word
+ FC_Drive01 Data[1]	0		Decimal	INT	Main Reference Value

Illustration 3.21 Tags for the Frequency Converter Created in the Controller Tags-window.

### 3.4 IP Traffic

The use of Ethernet-based network for industrial automation purposes calls for careful and thorough network design. Especially the use of active network components like switches and routers requires detailed know-how about the behavior of IP traffic.

Some important issues:

#### Multicast/Unicast

Multicast traffic is addressed to several recipients. Each host processes the received multicast packet to determine if it is the target for the packet. If not, the IP package is discarded. This causes an excessive network load of each node in the network since they are flooded with multicast packages. The nature of EtherNet/IP traffic is that all originator-to-target traffic is unicast (point-to-point), but target-to-originator traffic is optional multicast. This enables several listen-only connections to a single host. The EtherNet/IP control cassette supports both multicast and unicast traffic.

In switched networks, hosts also have the risk of becoming flooded with multicast traffic. A switch usually forwards traffic by MAC address tables built by looking into the source address field of all the frames it receives. A multicast MAC address is never used as a source address for a packet. Such addresses do not appear in the MAC address table, and the switch has no method for learning them, so it forwards all multicast traffic to all connected hosts.

#### IGMP

IGMP (internet group management protocol) is an integrated part of IP. It allows hosts to join or leave a multicast host group. Group membership information is exchanged between a specific host and the nearest multicast router.

For EtherNet/IP networks, the switches used must support IGMP snooping. IGMP snooping enables the switch to listen in on the IGMP conversation between hosts and routers. The switch then recognizes which hosts are members of which groups, thus being able to forward multicast traffic only to the appropriate hosts.

#### Redundancy

For an Ethernet network to function properly, only 1 active path can exist between 2 nodes. Spanning-tree protocol is a link management protocol that provides path redundancy while preventing undesirable loops in the network.

When loops occur, some switches see stations appearing on both sides. This condition confuses the forwarding algorithm and allows duplicate frames to be forwarded.

## 4 Control

### 4.1 I/O Assembly Instances

I/O assembly instances are some defined process control objects with defined content comprising control and status information.

Unlike DeviceNet, it is possible to run with asymmetrical instances. For example, 101/153 = 8 bytes/20 bytes.

It is not possible to mix instances across profiles, for example 20/100. Assembly instances must be consistent to the ODVA or frequency converter profile.

Read the controlling instance in *chapter 5.2.3 12-2\* Process Data*.

Profile (parameter 8-10 Control Word Profile)	Direction	Instances (decimal)	Size (bytes)	Data
ODVA	Originator⇒Target	20	4	CTW (20) REF
		21	4	CTW (21) REF
	Target⇒Originator	70	4	STW (70) MAV
		71	4	STW (71) MAV
Frequency converter	Originator⇒Target	100	4	CTW (FC) REF
		101	8	CTW (FC) REF PCD [2] PCD [3]
		103	20	CTW (FC) REF PCD [2] ... PCD [9]
	Target⇒Originator	150	4	STW (FC) MAV
		151	8	STW (FC) MAV PCD [2] PCD [9]
		153	20	STW (FC) MAV PCD [2] ... PCD [9]

Table 4.1 I/O Assembly Instance Options for Controlling and Monitoring the Frequency Converter

#### **NOTICE**

Use of 32-bit process data.

To configure a 2-word (32-bit) parameter read/write, use 2 consecutive arrays in *parameter 12-21 Process Data Config Write* and *parameter 12-22 Process Data Config Read*, like [2]+[3], [4]+[5], [6]+[7], and so on. Read/write of 2-word values in arrays like [3]+[4], [5]+[6], [7]+[8] is not possible.

## 4.2 EtherNet/IP Connections

The EtherNet/IP control cassette supports the CIP connections.

### 4.2.1 Class-1 Connection

I/O connection using TCP transport. The EtherNet/IP interface supports maximum 1 Class-1 connection, but several listen-only connections can be established if multicast is selected as transport type. This type of connection is used for cyclic I/O and change-of-state connections. The connection is established with a forward open-command, containing the following information:

#### Transport type

Specified for both directions:

- Originator-to-target/target-to-originator.
- Point-to-point.
- Multicast (target-to-originator only).

#### Data size

Specified (in bytes) for both directions:

- Originator⇒Target
- Target⇒Originator

The data size depends on the assembly instance selected in *Table 4.2*.

Instances (decimal)		Data size
Originator⇒target	Target⇒originator	
20, 21, 100	70, 71, 150	4 bytes
101	151	8 bytes
103	153	20 bytes

Table 4.2 Data Size

#### Packet rate

Specified (in ms) for both directions: Originator⇒target/Target⇒originator.

Minimum packet rate supported: 1 ms.

#### Production inhibit timeout

Specifies (in ms) the timeout time for both directions.

#### Trigger

Selects the transport trigger type:

- Cyclic (data is transmitted based on API).
- Change-of-state (data is transmitted on change-of-state only. COS filters are set up in *parameter 12-38 COS Filter*).

#### Connection points

Specified for both directions: Originator⇒target/Target⇒originator.

Profile (parameter 8-10 Control Word Profile)	Direction	Connection points (decimal)
ODVA	Originator ⇒target	20, 21
	Target ⇒originator	70, 71
Frequency converter	Originator⇒target	100, 101, 103
	Target ⇒originator	150, 151, 153

Table 4.3 Connection Points

### 4.2.2 Class-3 Connection

Cyclic connection using UDP transport.

Maximum 6 Class-3 connections are supported.

This type of connection is used for explicit messaging. The connection is established with a forward open-command, containing the following information:

#### Connection name

Given name for the connection.

#### Message parameters

- Service code.
- Class.
- Instance.
- Attribute.
- Member.
- Request data.

### 4.2.3 Unconnected Messages, UCMM

Non-cyclic connection using TCP transport.

This type of connection is used for explicit messaging. The connection is established on-the-fly and does not require any forward open-command.

#### Message parameters

- Service code.
- Class.
- Instance.
- Attribute.
- Member.
- Request data.

Refer to *chapter 7 Appendix* for information on accessing CIP objects explicitly.

### 4.2.4 Control Word Profile

The control profile is selected in *parameter 8-10 Control Word Profile*.

- ODVA gives access to the ODVA-specific profiles and assembly instances:
  - 20
  - 21
  - 70
  - 71
- FC profile enables the Danfoss profile and assembly instances:
  - 100
  - 101
  - 103
  - 150
  - 151
  - 153

For more information on the different profiles, refer to *chapter 4.3 FC Control Profile* and *chapter 4.4 ODVA Control Profile*.

**NOTICE**

**Change of control profile.**

**It is only possible to change the control profile while the frequency converter is stopped. Control word and reference are not recalculated to match the selected profile but are kept at the last good known value.**

### 4.2.5 Change-of-State, COS

The event-controlled operating mode is used to minimize network traffic. Messages are transmitted only if a defined state or value has changed. The insertion of COS filters determines the condition for triggering a COS message (*parameter 12-38 COS Filter*), for each bit in the different PCD-words.

The filter acts like a logical AND-function: If a bit in the filter is set to 1, the COS-function triggers when there is a change to the corresponding bit for the PCD-word.

To filter out undesired events for COS, use *Parameter 12-38 COS Filter*. If a filter bit is set to 0, the corresponding I/O instance bit is unable to produce a COS message. By default, all bits in the COS filters are set to 0.

To signal that the connection has not been interrupted, or the device is not powered off, a heartbeat message is transmitted within a specified time interval (heartbeat interval). This interval is defined in attribute heartbeat time of the connection object, Class 0x01.

To prevent the device from producing heavy network traffic when a value changes frequently, a production inhibit time is defined in *parameter 12-37 COS Inhibit Timer*. This parameter defines the minimum time between 2 COS messages. If *parameter 12-37 COS Inhibit Timer* is set to 0, the production inhibit timer is disabled.

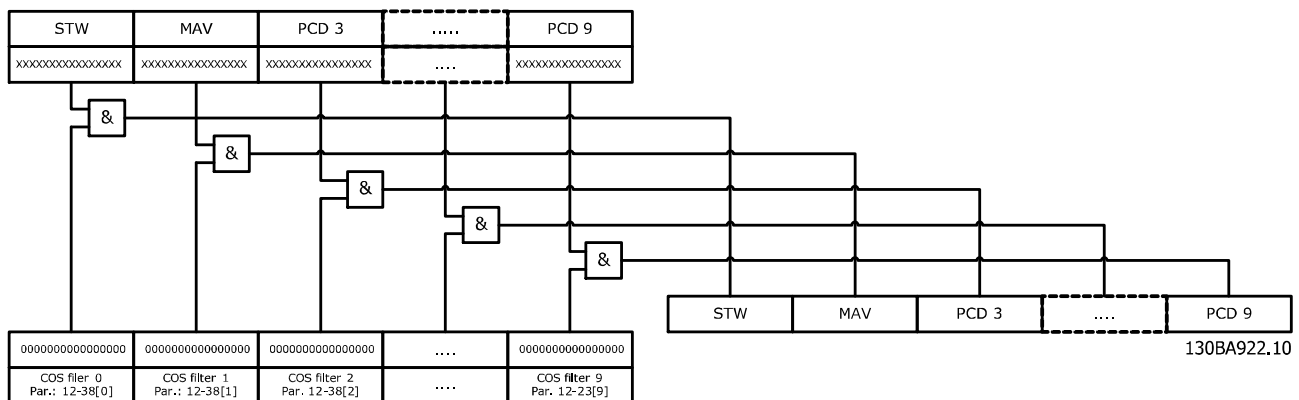

Illustration 4.1 Different PCDs and Corresponding Filter Parameters



### 4.3 FC Control Profile

#### 4.3.1 Control Word according to FC Profile

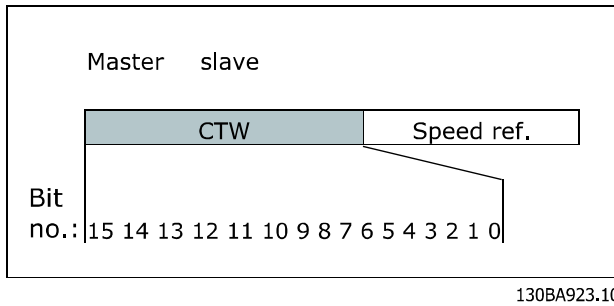

Illustration 4.2 FC Control Profile

Bit	Bit value = 0	Bit value = 1
00	Reference value	External selection lsb
01	Reference value	External selection msb
02	DC brake	Ramp
03	Coasting	No coasting
04	Quick stop	Ramp
05	Hold output frequency	Use ramp
06	Ramp stop	Start
07	No function	Reset
08	No function	Jog
09	Ramp 1	Ramp 2
10	Data invalid	Data valid
11	No function	Relay 01 active
12	No function	No function
13	Parameter set-up	Selection lsb
14	Parameter set-up	Selection msb
15	No function	Reverse

Table 4.4 Control Word Bits

#### Explanation of control bits

##### Bits 00/01

Select between the 4 reference values, which are pre-programmed in *parameter 3-10 Preset Reference* according to *Table 4.5*.

Programmed reference value	Parameter	Bit 01	Bit 00
1	3-10 [0]	0	0
2	3-10 [1]	0	1
3	3-10 [2]	1	0
4	3-10 [3]	1	1

Table 4.5 Reference Values

#### **NOTICE**

*Parameter 8-56 Preset Reference Select* defines how bit 00/01 gates with the corresponding function on the digital inputs.

##### Bit 02, DC brake

Bit 02 = 0: DC braking and stop. Set braking current and duration in *parameter 2-01 DC Brake Current* and *parameter 2-02 DC Braking Time*.

Bit 02 = 1: Ramping, see *parameter 3-41 Ramp 1 Ramp Up Time*.

##### Bit 03, Coasting

Bit 03 = 0: The frequency converter releases the motor immediately (the output transistors are shut off), so that it coasts to a standstill.

Bit 03 = 1: The frequency converter starts the motor when all starting conditions are fulfilled.

#### **NOTICE**

*Parameter 8-50 Coasting Select* defines how bit 03 gates with the corresponding function on a digital input.

##### Bit 04, Quick stop

Bit 04 = 0: A stop ramps down motor speed to stop via *parameter 3-81 Quick Stop Ramp Time*.

Bit 04 = 01: The frequency converter starts the motor when all starting conditions are fulfilled.

##### Bit 05, Hold output frequency

Bit 05 = 0: The present output frequency (in Hz) freezes. To change the frozen output frequency, set the digital inputs to [21] *Speed up* and [22] *Speed down* in *parameter 5-10 Terminal 18 Digital Input* to *parameter 5-15 Terminal 33 Digital Input*.

#### **NOTICE**

If freeze output is active, the frequency converter can only be stopped by the following:

- Bit 03 Coasting stop.
- Bit 02 DC braking.
- Digital input (*parameter 5-10 Terminal 18 Digital Input* to *parameter 5-15 Terminal 33 Digital Input*) programmed to DC braking, Coasting stop, or Reset and coasting stop.

##### Bit 06, Ramp stop/start

Bit 06 = 0: A stop ramps down motor speed to stop via the selected ramp-down parameter.

Bit 06 = 1: The frequency converter starts the motor when all starting conditions are fulfilled.

#### **NOTICE**

*Parameter 8-53 Start Select* defines how bit 06 Ramp stop/start gates with the corresponding function on a digital input.

##### Bit 07, Reset

Bit 07 = 0: No reset.

Bit 07 = 1: Reset of trip. Reset is activated on the leading edge of the signal, that is, when changing from logic 0 to logic 1.

**Bit 08, Jog**

Bit 08 = 0: The frequency converter uses the reference as setpoint for the motor speed.

Bit 08 = 1: Uses *parameter 3-19 Jog Speed [RPM]* as the setpoint for motor speed.

**Bit 09, Selection of ramp 1/2**

Bit 09 = 0: Ramp 1 is active (*parameter 3-40 Ramp 1 Type to parameter 3-47 Ramp 1 S-ramp Ratio at Decel. Start*).

Bit 09 = 1: Ramp 2 (*parameter 3-50 Ramp 2 Type to parameter 3-57 Ramp 2 S-ramp Ratio at Decel. Start*) is active.

**Bit 10, Data not valid/Data valid**

Bit 10 tells the frequency converter whether to use or ignore the control word.

Bit 10 = 0: The control word is ignored, giving the opportunity to turn off the control word when updating/reading parameters.

Bit 10 = 1: The control word is used. This function is relevant, because the control word is always contained in the telegram, regardless of which type of telegram is used.

**Bit 11, Relay 01**

Bit 11 = 0: Relay 01 not activated.

Bit 11 = 1: Relay 01 activated, if [36] *Control word bit 11* is selected in *parameter 5-40 Function Relay*.

**Bit 13/14, Selection of set-up**

Bits 13 and 14 are used to select 1 of 4 menu set-ups according to *Table 4.6*:

Set-up	Bit 14	Bit 13
1	0	0
2	0	1
3	1	0
4	1	1

Table 4.6 Menu Set-ups

The function is only possible when [9] *Multi Set-ups* is selected in *parameter 0-10 Active Set-up*.

**NOTICE**

*Parameter 8-55 Set-up Select* defines how bits 13/14 gate with the corresponding function on the digital inputs.

**Bit 15 Reverse**

Bit 15 = 0: No reversing.

Bit 15 = 1: Reversing.

**NOTICE**

In the factory setting, reversing is set to [0] *Digital input* in *parameter 8-54 Reversing Select*. Bit 15 causes reversing only when Ser. communication, Logic AND, or Logic OR is selected.

4.3.2 Status Word according to FC Profile

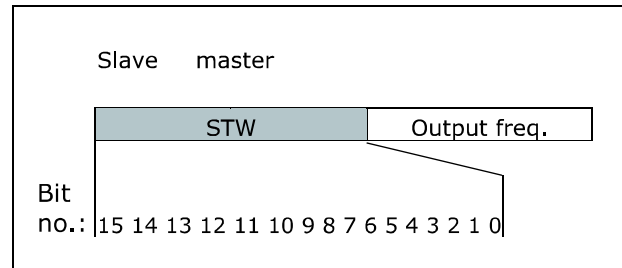

130BA924.10

Illustration 4.3 Parameter 8-10 Control Word Profile

Bit	Bit value = 0	Bit value = 1
00	Control not ready	Control ready
01	Drive not ready	Drive ready
02	Coasting	Enable
03	No error	Trip
04	No error	Error (no trip)
05	Reserved	-
06	No error	Trip lock
07	No warning	Warning
08	Speed ≠ reference	Speed = reference
09	Local operation	Bus control
10	Out of frequency limit	Frequency limit ok
11	No operation	In operation
12	Drive ok	Stopped, auto start
13	Voltage ok	Voltage exceeded
14	Torque ok	Torque exceeded
15	Thermal ok	Thermal exceeded

Table 4.7 Status Word Bits

**Explanation of the status bits**

**Bit 00, Control ready**

Bit 00 = 0: The frequency converter has tripped.

Bit 00 = 1: The frequency converter controls are ready, but the power component is not necessarily receiving any power supply (in the event of 24 V external supply to controls).

**Bit 01, Drive ready**

Bit 01 = 1: The frequency converter is ready for operation.

**Bit 02, Coasting stop**

Bit 02 = 0: The frequency converter has released the motor.

Bit 02 = 1: The frequency converter can start the motor when a start command is given.

**Bit 03, No error/Trip**

Bit 03 = 0: The frequency converter is not in fault mode.

Bit 03 = 1: The frequency converter is tripped, and a reset signal is required to re-establish operation.

**Bit 04, No error/Error (no trip)**

Bit 04 = 0: The frequency converter is not in fault mode.

Bit 04 = 1: There is a frequency converter fault but no trip.

**Bit 05, Reserved**

Bit 05 is not used in the status word.

**Bit 06, No error/Trip lock**

Bit 06 = 0: The frequency converter is not in fault mode.  
 Bit 06 = 1: The frequency converter is tripped and locked.

**Bit 07, No warning/Warning**

Bit 07 = 0: There are no warnings.  
 Bit 07 = 1: A warning is active.

**Bit 08, Speed ≠ reference/Speed = reference**

Bit 08 = 0: The motor runs, but the present speed is different from the preset speed reference. For example, it may occur while the speed is being ramped up/down during start/stop.  
 Bit 08 = 1: The present motor speed matches the preset speed reference.

**Bit 09, Local operation/Bus control**

Bit 09 = 0: [Stop/Reset] is pressed on the control unit, or [2] Local is selected in *parameter 3-13 Reference Site*. It is not possible to control the frequency converter via serial communication.  
 Bit 09 = 1: It is possible to control the frequency converter via the fieldbus/serial communication.

**Bit 10, Out of frequency limit**

Bit 10 = 0: The output frequency has reached the value in *parameter 4-11 Motor Speed Low Limit [RPM]* or *parameter 4-13 Motor Speed High Limit [RPM]*.  
 Bit 10 = 1: The output frequency is within the defined limits.

**Bit 11, No operation/In operation**

Bit 11 = 0: The motor does not run.  
 Bit 11 = 1: The frequency converter has a start signal, or the output frequency is greater than 0 Hz.

**Bit 12, Drive OK/Stopped, auto start**

Bit 12 = 0: There is no temporary overtemperature on the frequency converter.  
 Bit 12 = 1: The frequency converter has stopped because of overtemperature, but the unit has not tripped and resumes operation once the temperature is below the maximum limit.

**Bit 13, Voltage OK/Voltage exceeded**

Bit 13 = 0: There are no voltage warnings.  
 Bit 13 = 1: The DC voltage in the frequency converter's DC link is too low or too high.

**Bit 14, Torque OK/Torque limit exceeded**

Bit 14 = 0: The motor torque is lower than the torque limit selected in *parameter 4-16 Torque Limit Motor Mode* and *parameter 4-17 Torque Limit Generator Mode*.  
 Bit 14 = 1: The torque limit in *parameter 4-16 Torque Limit Motor Mode* or *parameter 4-17 Torque Limit Generator Mode* is exceeded. Read the nominal torque in *parameter 16-16 Torque [Nm]*.

**Bit 15, Thermal OK/Limit exceeded**

Bit 15 = 0: The timers for both motor thermal protection and frequency converter thermal protection have not exceeded 100%.  
 Bit 15 = 1: One of the limits has exceeded 100%.

**4.4 ODVA Control Profile**

**4.4.1 Control Word under Instances 20/70 and 21/71**

Set *parameter 8-10 Control Word Profile* to ODVA.

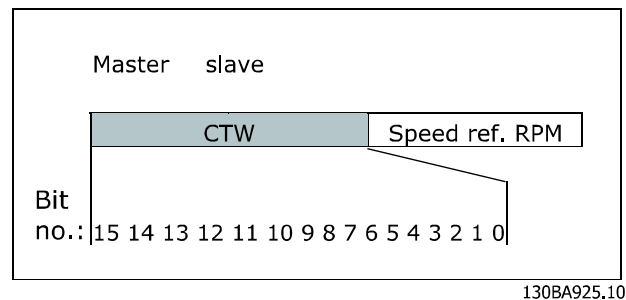

Illustration 4.4 Control Word in Instances 20 and 21

**NOTICE**

Bits 00 and 02 in instance 20 are identical to bits 00 and 02 in the more extensive instance 21.

Bit	Instance 20		Instance 21	
	Bit = 0	Bit = 1	Bit = 0	Bit = 1
00	Stop	Run	Fwd stop	Run fwd
01	–	–	Stop	Run rev
02	No function	Fault reset	No function	Fault reset
03	–	–	–	–
04	–	–	–	–
05	–	–	–	Net ctrl
06	–	–	–	Net ref
07–15	–	–	–	–

Table 4.8 Control Word Bits in Instances 20 and 21

**Explanation of the bits**

**Bit 0, Run fwd**

Bit 0 = 0: The frequency converter has a stop command.  
 Bit 0 = 1: The frequency converter starts the motor in clockwise direction.

**Bit 1, Run rev**

Bit 0 = 0: The frequency converter has a stop command.  
 Bit 0 = 1: The frequency converter runs the motor in counterclockwise direction.

**Bit 2, Fault reset**

Bit 2 = 0: There is no trip reset.  
 Bit 2 = 1: A trip is reset.

**Bit 3, No function**

Bit 3 has no function.

**Bit 4, No function**

Bit 4 has no function.

**Bit 5, Net control**

Bit 5 = 0: The frequency converter is controlled from the standard inputs.  
 Bit 5 = 1: EIP controls the frequency converter.

**NOTICE**

Changes affect *parameter 8-50 Coasting Select* to *parameter 8-56 Preset Reference Select*.

**Bit 6, Net reference**

Bit 6 = 0: Reference is from the standard inputs.  
 Bit 6 = 1: Reference is from EIP.

**NOTICE**

Changes affect *parameter 3-15 Reference Resource 1* to *parameter 3-17 Reference Resource 3*. For the speed reference, see *chapter 4.5.2 Bus Speed Reference Value under Instances 20/70 and 21/71*.

**4.4.2 Status Word under Instances 20/70 and 21/71**

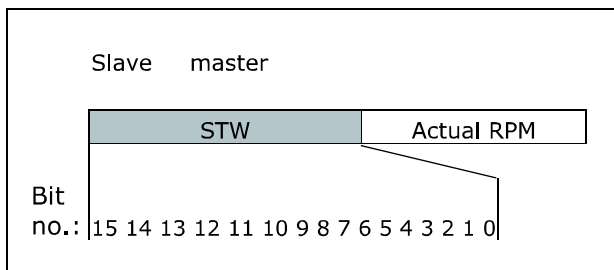

Illustration 4.5 Status Word in Instances 70 and 71

**NOTICE**

Bits 00 and 02 in instance 70 are identical to bits 00 and 02 in the more extensive instance 71.

Bit	Instance 70		Instance 71	
	Bit = 0	Bit = 1	Bit = 0	Bit = 1
00	No fault	Fault	No fault	Fault
01	–	–	No warning	Warning
02	–	Running 1 fwd	–	Running 1 fwd
03	–	–	–	Running 2 rev
04	–	–	–	Ready
05	–	–	–	Ctrl from net
06	–	–	–	Ref. from net
07	–	–	–	At reference
08–15	–	–	State attribute	

Table 4.9 Status Word Bits in Instances 70 and 71

**Explanation of the bits**

**Bit 0, Fault**

Bit 0 = 0: There is no fault in the frequency converter.  
 Bit 0 = 1: There is a fault in the frequency converter.

**Bit 1, Warning**

Bit 0 = 0: There is no unusual situation.  
 Bit 0 = 1: An abnormal condition has occurred.

**Bit 2, Running 1**

Bit 2 = 0: The frequency converter is not in 1 of these states, or Run 1 is not set.  
 Bit 2 = 1: The frequency converter state attribute is enabled or stopping, or fault-stop and bit 0 (Run 1) of the control word are set at the same time.

**Bit 3, Running 2**

Bit 3 = 0: The frequency converter is in neither of these states, or Run 2 is not set.  
 Bit 3 = 1: The frequency converter state attribute is enabled or stopping, or fault-stop and bit 0 (Run 2) of the control word are set at the same time.

**Bit 4, Ready**

Bit 4 = 0: The state attribute is in another state.  
 Bit 4 = 1: The state attribute is ready, enabled, or stopping.

**Bit 5, Control from net**

Bit 5 = 0: The frequency converter is controlled from the standard inputs.  
 Bit 5 = 1: EIP has control (start, stop, reverse) of the frequency converter.

**Bit 6, Ref from net**

Bit 6 = 0: The reference comes from inputs to the frequency converter.  
 Bit 6 = 1: The reference comes from EIP.

**Bit 7, At reference**

Bit 7 = 0: The motor runs, but the present speed is different from the preset speed reference, that is, the speed is ramped up/down during start/stop.  
 Bit 7 = 1: The frequency converter and reference speeds are equal.

**Bits 8–15, State attribute**

(Instance 71 only) Shows the state attribute of the frequency converter as indicated in Table 4.10:

Bit number	Meaning
8	Not used
9	Start up
10	Not ready
11	Ready
12	Enabled
13	Stopping
14	Fault stop
15	Faulted

For more detail of the actual output speed, see chapter 4.5.2 *Bus Speed Reference Value under Instances 20/70 and 21/71.*

Table 4.10 State Attribute of the Frequency Converter

**4.5 Reference Handling**

**4.5.1 Bus Speed Reference Value**

In FC profile (*parameter 8-10 Control Word Profile = [0] Frequency converter profile*), the reference is scaled as a normalized relative value in percent. The value is transmitted in hexadecimal:

- 0% = 0 hex
- 100% = 4000 hex
- -100% = C000 hex

Depending on the setting of *parameter 3-00 Reference Range*, the reference is scaled from -maximum to +maximum or from minimum to maximum.

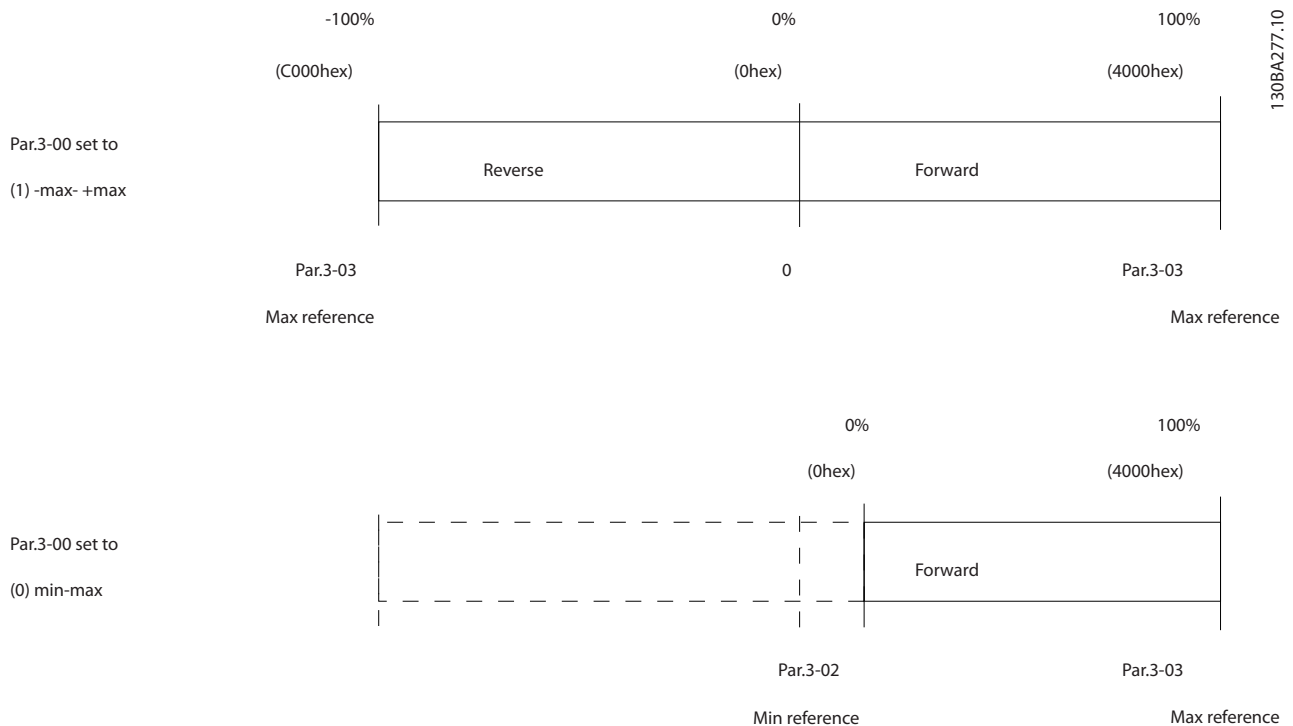

Illustration 4.6 Scaling of Reference Values

The actual reference [Ref. %] in the frequency converter depends on the settings in the following parameters:

- *Parameter 1-23 Motor Frequency*
- *Parameter 1-25 Motor Nominal Speed*
- *Parameter 3-02 Minimum Reference*
- *Parameter 3-03 Maximum Reference*

All references provided to the frequency converter are added to the total reference value. When the fieldbus controls a reference only, ensure that all other reference inputs are 0.

Digital and analog input terminals cannot be used for reference signals. The default setting (0%) can be maintained for preset references in *parameter 3-10 Preset Reference*.

### **NOTICE**

If the bus speed reference is negative, and the control word contains a run reverse signal, the frequency converter runs clockwise (- to - is +).

MAV is scaled in the same way as the reference.

#### 4.5.2 Bus Speed Reference Value under Instances 20/70 and 21/71

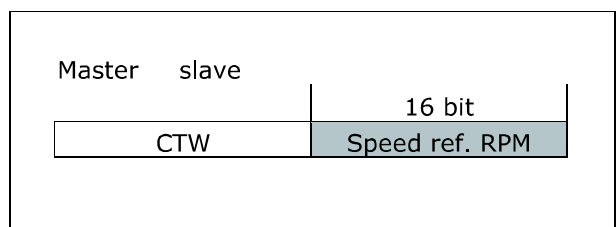

130BA941.10

**Illustration 4.7** Bus Speed Reference Value under Instances 20/70 and 21/71

The speed reference value is transmitted to the frequency converter in the form of a 16-bit word. The value is transmitted directly in RPM.

## 5 Parameters

### 5.1 Parameter Group 8-\*\* Communication and Option

#### 5.1.1 8-0\* General Settings

8-01 Control Site		
Option:	Function:	
		The setting in this parameter overrides the settings in <i>parameter 8-50 Coasting Select</i> to <i>parameter 8-58 Profidrive OFF3 Select</i> .
[0] *	Digital and ctrl.word	Control by using both digital input and control word.
[1]	Digital only	Control by using digital inputs only.
[2]	Controlword only	Control by using control word only.

8-02 Control Source		
Option:	Function:	
		<p><b>NOTICE</b> This parameter cannot be adjusted while the motor is running.</p> <p>Select the source of the control word: 1 of 2 serial interfaces or 4 installed options. During initial power-up, the frequency converter automatically sets this parameter to [3] <i>Option A</i> if it detects a valid fieldbus option installed in slot A. When the option is removed, the frequency converter detects a configuration change, sets <i>parameter 8-02 Control Word Source</i> to default setting [1] <i>FC RS485</i>, and trips. If an option is installed after initial power-up, the setting of <i>parameter 8-02 Control Word Source</i> does not change, but the frequency converter trips and shows <i>alarm 67, Option Changed</i>.</p> <p>When retrofitting a bus option into a frequency converter that did not have a bus option installed earlier, change the control to bus-based. This change is required for safety reasons to avoid an unintended change.</p>
[0]	None	
[1]	FC Port	
[2]	FC USB	
[3]	Option A	

8-03 Control Timeout Time		
Range:	Function:	
1 s*	[0.1 - 6000 s]	Enter the maximum time expected to pass between the reception of 2 consecutive telegrams. If this time is exceeded, it indicates that the telegram communication has stopped. The function selected in <i>parameter 8-04 Control Word Timeout Function</i> is then carried out. A valid control word triggers the timeout counter.

8-04 Control Timeout Function		
Select the timeout function. The timeout function activates when the control word fails to be updated within the time period specified in <i>parameter 8-03 Control Word Timeout Time</i> .		
Option:	Function:	
		<p><b>NOTICE</b> To change the set-up after a timeout, configure as follows:</p> <ol style="list-style-type: none"> <li>Set <i>parameter 0-10 Active Set-up</i> to [9] <i>Multi set-up</i>.</li> <li>Select the relevant link in <i>parameter 0-12 This Set-up Linked to</i>.</li> </ol>
[0] *	Off	Resume control via fieldbus (fieldbus or standard), using the most recent control word.
[1]	Freeze output	Freeze output frequency until communication resumes.
[2]	Stop	Stop with auto restart when communication resumes.
[3]	Jogging	Run the motor at jog frequency until communication resumes.
[4]	Max. speed	Run the motor at maximum frequency until communication resumes.
[5]	Stop and trip	Stop the motor, then reset the frequency converter to restart: <ul style="list-style-type: none"> <li>Via the fieldbus.</li> <li>Via [Reset].</li> <li>Via a digital input.</li> </ul>

8-07 Diagnosis Trigger		
Option:	Function:	
		Enable and control the frequency converter diagnosis function.
[0] *	Disable	Extended diagnosis data is not sent even if the data appears in the frequency converter.

8-07 Diagnosis Trigger		
Option:	Function:	
[1]	Trigger on alarms	Extended diagnosis data is sent when 1 or more alarms appear.
[2]	Trigger alarm/warn.	Extended diagnosis data is sent if 1 or more alarms/warnings appear.

### 5.1.2 8-1\* Ctrl. Word Settings

8-10 Control Word Profile		
Select the interpretation of the control and status words corresponding to the installed fieldbus. Only the selections valid for the fieldbus installed are visible in the LCP display. For guidelines in selection of [0] <i>Frequency converter profile</i> and [1] <i>PROFdrive profile</i> , refer to the <i>design guide</i> for the frequency converter.		
Option:	Function:	
[0] *	FC profile	
[1]	PROFdrive profile	
[5]	ODVA	
[7]	CANopen DSP 402	

8-14 Configurable Control Word CTW		
Option:	Function:	
		Selection of control word bit 10 if it is active low or active high.
[0]	None	
[1] *	Profile default	
[2]	CTW Valid, active low	
[4]	PID error inverse	
[5]	PID reset I part	
[6]	PID enable	

8-19 Product Code		
Range:	Function:	
Size related* [0 - 2147483647]	Select 0 to read out the actual fieldbus product code according to the mounted fieldbus option. Select 1 to read out the actual vendor ID.	

### 5.1.3 8-3\* FC Port Settings

8-30 Protocol		
Option:	Function:	
		Select the protocol for the integrated RS485 port.
[0] *	FC	Communication according to the FC protocol.
[2]	Modbus RTU	Communication according to the Modbus RTU protocol.

8-31 Address		
Range:	Function:	
1* [ 0.0 - 247 ]	Enter the address for the RS485 port. Valid range: 1–126 for FC-bus or 1–247 for Modbus.	

8-32 Baud Rate		
Option:	Function:	
		Select the baud rate for the RS485 port.
[0]	2400 Baud	
[1]	4800 Baud	
[2]	9600 Baud	
[3]	19200 Baud	
[4]	38400 Baud	
[5]	57600 Baud	
[6]	76800 Baud	
[7]	115200 Baud	

8-33 Parity / Stop Bits		
Option:	Function:	
[0] *	Even Parity, 1 Stop Bit	
[1]	Odd Parity, 1 Stop Bit	
[2]	No Parity, 1 Stop Bit	
[3]	No Parity, 2 Stop Bits	

8-35 Minimum Response Delay		
Range:	Function:	
0.01 s* [ 0.0010 - 0.5 s]	Specify the minimum delay time between receiving a request and transmitting a response. This is used for overcoming modem turn-around delays.	

8-36 Maximum Response Delay		
Range:	Function:	
Size related* [ 0.1 - 10.0 s]	Specify the maximum allowed delay time between receiving a request and transmitting the response. If this time is exceeded, no response is returned.	

8-37 Maximum Inter-char delay		
Range:	Function:	
0.025 s* [ 0.025 - 0.025 s]	Specify the maximum delay time between 2 characters in a message. Exceeding this delay time causes the message to be discarded.	



### 5.1.4 8-4\* FC MC Protocol Set

8-42 PCD Write Configuration		
Enter up to 16 different preset mapping 0–15 in this parameter, using array programming. If this parameter is active, addresses 2810–2825 represent values of the 16 parameters. If this parameter is not active, addresses 2810 and 2811 are used as input-data-drive control word and bus reference. Addresses 2812–2825 are reserved.		
Option:	Function:	
[0]	None	
[1]	[302] Minimum Reference	
[2]	[303] Maximum Reference	
[3]	[341] Ramp 1 Ramp up time	
[4]	[342] Ramp 1 Ramp down time	
[5]	[351] Ramp 2 Ramp up time	
[6]	[352] Ramp 2 Ramp down time	
[7]	[380] Jog Ramp Time	
[8]	[381] Quick Stop Time	
[9]	[412] Motor Speed Low Limit [Hz]	
[10]	[414] Motor Speed High Limit [Hz]	
[11]	[590] Digital & Relay Bus Control	
[12]	[676] Terminal45 Output Bus Control	
[13]	[696] Terminal 42 Output Bus Control	
[14]	[894] Bus Feedback 1	
[15]	FC Port CTW	
[16]	FC Port REF	

8-43 PCD Read Configuration		
Enter up to 16 different preset mapping (0-15) in this parameter, using array programming. If this parameter is active, addresses from 2910 to 2925 represent values of the 16 parameters. If this parameter is not active, addresses 2910 and 2911 are used as status word register and main actual value. Addresses from 2912 to 2925 are reserved.		
Option:	Function:	
[0]	None	
[1]	[1500] Operation Hours	
[2]	[1501] Running Hours	
[3]	[1502] kWh Counter	
[4]	[1600] Control Word	
[5]	[1601] Reference [Unit]	
[6]	[1602] Reference %	
[7]	[1603] Status Word	
[8]	[1605] Main Actual Value [%]	
[9]	[1609] Custom Readout	
[10]	[1610] Power [kW]	
[11]	[1611] Power [hp]	

8-43 PCD Read Configuration		
Enter up to 16 different preset mapping (0-15) in this parameter, using array programming. If this parameter is active, addresses from 2910 to 2925 represent values of the 16 parameters. If this parameter is not active, addresses 2910 and 2911 are used as status word register and main actual value. Addresses from 2912 to 2925 are reserved.		
Option:	Function:	
[12]	[1612] Motor Voltage	
[13]	[1613] Frequency	
[14]	[1614] Motor Current	
[15]	[1615] Frequency [%]	
[16]	[1616] Torque [Nm]	
[17]	[1618] Motor Thermal	
[18]	[1630] DC Link Voltage	
[19]	[1634] Heatsink Temp.	
[20]	[1635] Inverter Thermal	
[21]	[1638] SL Controller State	
[22]	[1650] External Reference	
[23]	[1652] Feedback [Unit]	
[24]	[1660] Digital Input 18,19,27,33	
[25]	[1661] Terminal 53 Switch Setting	
[26]	[1662] Analog Input 53(V)	
[27]	[1663] Terminal 54 Switch Setting	
[28]	[1664] Analog Input 54	
[29]	[1665] Analog Output 42 [mA]	
[30]	[1671] Relay Output [bin]	
[31]	[1672] Counter A	
[32]	[1673] Counter B	
[33]	[1690] Alarm Word	
[34]	[1692] Warning Word	
[35]	[1694] Ext. Status Word	

### 5.1.5 8-5\* Digital/Bus

Parameters for configuring the control word merging.

#### NOTICE

These parameters are active only when parameter 8-01 Control Site is set to [0] Digital and control word.

8-50 Coasting Select		
Option:	Function:	
		Select the trigger for the coasting function.
[0]	Digital input	A digital input triggers the coasting function.
[1]	Bus	A serial communication port or the fieldbus triggers the coasting function.
[2]	Logic AND	The fieldbus/serial communication port and a digital input trigger the coasting function.

8-50 Coasting Select		
Option:	Function:	
[3] *	Logic OR	The fieldbus/serial communication port or a digital input triggers the coasting function.

8-51 Quick Stop Select		
Select the trigger for the quick stop function.		
Option:	Function:	
[0]	Digital input	
[1]	Bus	
[2]	Logic AND	
[3] *	Logic OR	

8-52 DC Brake Select		
Option:	Function:	
		Select control of the DC brake via the terminals (digital input) and/or via the fieldbus. <b>NOTICE</b> When <i>parameter 1-10 Motor Construction</i> is set to [1] PM non-salient SPM, only selection [0] Digital input is available.
[0]	Digital input	Activate a start command via a digital input.
[1]	Bus	Activate a start command via the serial communication port or fieldbus option.
[2]	Logic AND	Activate a start command via the fieldbus/serial communication port and via 1 of the digital inputs.
[3] *	Logic OR	Activate a start command via the fieldbus/serial communication port or via 1 of the digital inputs.

8-53 Start Select		
Option:	Function:	
		Select the trigger for the start function.
[0]	Digital input	A digital input triggers the start function.
[1]	Bus	A serial communication port or the fieldbus triggers the start function.
[2]	Logic AND	The fieldbus/serial communication port and a digital input trigger the start function.
[3] *	Logic OR	The fieldbus/serial communication port or a digital input triggers the start function.

8-54 Reversing Select		
Option:	Function:	
		Select the trigger for the reversing function.
[0]	Digital input	A digital input triggers the reversing function.
[1]	Bus	A serial communication port or the fieldbus triggers the reversing function.

8-54 Reversing Select		
Option:	Function:	
[2]	Logic AND	The fieldbus/serial communication port and a digital input trigger the reversing function.
[3]	Logic OR	The fieldbus/serial communication port or a digital input triggers the reversing function.

8-55 Set-up Select		
Option:	Function:	
		Select the trigger for the set-up selection.
[0]	Digital input	A digital input triggers the set-up selection.
[1]	Bus	A serial communication port or the fieldbus triggers the set-up selection.
[2]	Logic AND	The fieldbus/serial communication port and a digital input trigger the set-up selection.
[3] *	Logic OR	The fieldbus/serial communication port or a digital input triggers the set-up selection.

8-56 Preset Reference Select		
Option:	Function:	
		Select the trigger for the preset reference selection.
[0]	Digital input	A digital input triggers the preset reference selection.
[1]	Bus	A serial communication port or the fieldbus triggers the preset reference selection.
[2]	Logic AND	The fieldbus/serial communication port and a digital input trigger the preset reference selection.
[3] *	Logic OR	The fieldbus/serial communication port or a digital input triggers the preset reference selection.

8-57 Profdrive OFF2 Select		
Option:	Function:	
[0]	Digital input	
[1]	Bus	
[2]	Logic AND	
[3] *	Logic OR	

8-58 Profdrive OFF3 Select		
Option:	Function:	
[0]	Digital input	
[1]	Bus	
[2]	Logic AND	
[3] *	Logic OR	

### 5.1.6 8-7\* Protocol SW Version

8-79 Protocol Firmware version		
Range:	Function:	
Size related*	[0 - 65535]	Firmware revision: FC is in index 0; Modbus is in index 1; indexes 2-4 are reserved.

### 5.1.7 8-8\* FC Port Diagnostics

These parameters are used for monitoring the bus communication via the frequency converter port.

8-80 Bus Message Count		
Range:	Function:	
0*	[0 - 4294967295]	This parameter shows the number of valid telegrams detected on the bus.

8-81 Bus Error Count		
Range:	Function:	
0*	[0 - 4294967295]	This parameter shows the number of telegrams with faults (for example CRC faults) detected on the bus.

8-82 Slave Messages Rcvd		
Range:	Function:	
0*	[0 - 4294967295]	This parameter shows the number of valid telegrams sent by the frequency converter to the slave.

8-83 Slave Error Count		
Range:	Function:	
0*	[0 - 4294967295]	This parameter shows the number of error telegrams, which could not be executed by the frequency converter.

8-84 Slave Messages Sent		
Range:	Function:	
0*	[0 - 4294967295]	This parameter shows the number of messages sent from the slave.

8-85 Slave Timeout Errors		
Range:	Function:	
0*	[0 - 4294967295]	This parameter shows the number of slave timeout errors.

8-88 Reset FC port Diagnostics		
Option:	Function:	
[0] *	Do not reset	Do not reset all FC port diagnostic counters.
[1]	Reset counter	Reset all FC port diagnostic counters.

### 5.1.8 8-9\* Bus Feedback

Use the parameter group to configure the bus feedback.

8-90 Bus Jog 1 Speed		
Range:	Function:	
100 RPM*	[0 - 1500 RPM]	Enter the jog speed. Activate this fixed jog speed via the serial port or fieldbus option.

8-91 Bus Jog 2 Speed		
Range:	Function:	
200 RPM*	[0 - 1500 RPM]	Enter the jog speed. Activate this fixed jog speed via the serial port or fieldbus option.

## 5.2 Parameter Group 12-\*\* Ethernet

### 5.2.1 12-0\* IP Settings

12-00 IP Address Assignment		
Option:	Function:	
		Select the IP address assignment method.
[0]	MANUAL	IP address can be set in <i>parameter 12-01 IP Address</i> IP Address.
[1]	DHCP	IP address is assigned via DHCP server.
[2]	BOOTP	IP address is assigned via BOOTP server.
[10] *	DCP	DCP is assigned via the DCP protocol.
[20]	From node ID	

12-01 IP Address		
Range:	Function:	
0*	[0 - 4294967295]	Configure the IP address of the option. Read-only, if <i>parameter 12-00 IP Address Assignment</i> is set to DHCP or BOOTP. In POWERLINK, the IP address follows the <i>parameter 12-60 Node ID</i> last byte and the first part is fixed to 192.168.100 (node ID).

12-02 Subnet Mask		
Range:	Function:	
0*	[0 - 4294967295]	Configure the IP subnet mask of the option. Read-only, if <i>parameter 12-00 IP Address Assignment</i> is set to DHCP or BOOTP. In POWERLINK, it is fixed to 255.255.255.0.

**12-03 Default Gateway**

Range:	Function:
0* [0 - 4294967295]	Configure the IP default gateway of the option. Read-only, if <i>parameter 12-00 IP Address Assignment</i> is set to DHCP or BOOTP. In a non-routed network, this address is set to the IP address of the IO Device.

**12-04 DHCP Server**

Range:	Function:
0* [0 - 2147483647]	Read-only. Show the IP address of the found DHCP or BOOTP server.

**12-05 Lease Expires**

Range:	Function:
0* [0 - 4294967295]	Read-only. Show the lease time left for the current DHCP-assigned IP address.

**12-06 Name Servers**

Range:	Function:
0* [0 - 4294967295]	IP addresses of domain name servers. Can be automatically assigned when using DHCP.

**12-07 Domain Name**

Range:	Function:
0 [1 - 48]	Domain name of the attached network. Can be automatically assigned when using DHCP network.

**12-08 Host Name**

Range:	Function:
0* [0 - 48]	Logical (given) name of option.  <b>NOTICE</b> The display of the frequency converter only shows the first 19 characters, but the remaining characters are stored in the frequency converter. If hardware switches are different from all ON or all OFF, the switches have priority.

**12-09 Physical Address**

Range:	Function:
0* [0 - 17]	Read-only. Show the physical (MAC) address of the option.

5.2.2 12-1\* Ethernet Link Parameters

Apply to the whole parameter group.

Index [0] is used for port 1, and index [1] is used for port 2.

**12-10 Link Status**

Option:	Function:
	Read-only. Show the link status of the Ethernet ports.
[0] *	No Link
[1]	Link

**12-11 Link Duration**

Range:	Function:
Size related* [0 - 0]	Read-only. Show the duration of the present link on each port in dd:hh:mm:ss.

**12-12 Auto Negotiation**

Option:	Function:
	Configure auto negotiation of Ethernet link parameters, for each port: ON or OFF.
[0]	Off <i>Link Speed</i> and <i>Link Duplex</i> can be configured in <i>parameter 12-13 Link Speed</i> and <i>parameter 12-14 Link Duplex</i> .
[1] *	On

**12-13 Link Speed**

Option:	Function:
	Force the link speed for each port in 10 Mbps or 100 Mbps. If <i>parameter 12-12 Auto Negotiation</i> is set to [1] On, this parameter is read-only and shows the actual link speed. If no link is present, None is shown.
[0] *	None
[1]	10 Mbps
[2]	100 Mbps

**NOTICE**

In POWERLINK, this parameter is locked to 100 Mbs.

**12-14 Link Duplex**

Option:	Function:
	<b>NOTICE</b> In POWERLINK, this parameter is locked to half duplex.  Force the duplex for each port to full or half duplex. If <i>parameter 12-12 Auto Negotiation</i> is set to [1] On, this parameter is read-only.
[0]	Half Duplex
[1]	Full Duplex

12-18 Supervisor MAC		
Range:	Function:	
0*	[0 - 2147483647]	Show the MAC address of currently active supervisor.

12-19 Supervisor IP Addr.		
Range:	Function:	
0*	[0 - 2147483647]	Show the IP Address of currently active supervisor.

### 5.2.3 12-2\* Process Data

12-20 Control Instance		
Range:	Function:	
Size related*	[0 - 255]	Show the originator-to-target connection point. If no CIP connection is present, none is shown.

12-21 Process Data Config Write		
Option:	Function:	
[0] *	None	
[302]	Minimum Reference	
[303]	Maximum Reference	
[312]	Catch up/slow Down Value	
[341]	Ramp 1 Ramp Up Time	
[342]	Ramp 1 Ramp Down Time	
[351]	Ramp 2 Ramp Up Time	
[352]	Ramp 2 Ramp Down Time	
[380]	Jog Ramp Time	
[381]	Quick Stop Ramp Time	
[412]	Motor Speed Low Limit [Hz]	
[414]	Motor Speed High Limit [Hz]	
[416]	Torque Limit Motor Mode	
[417]	Torque Limit Generator Mode	
[553]	Term. 29 High Ref./Feedb. Value	
[558]	Term. 33 High Ref./Feedb. Value	
[590]	Digital & Relay Bus Control	
[593]	Pulse Out 27 Bus Control	
[615]	Terminal 53 High Ref./Feedb. Value	
[625]	Terminal 54 High Ref./Feedb. Value	
[696]	Terminal 42 Output Bus Control	
[748]	PCD Feed Forward	
[890]	Bus Jog 1 Speed	
[891]	Bus Jog 2 Speed	
[1680]	Fieldbus CTW 1	
[1682]	Fieldbus REF 1	
[3401]	PCD 1 Write For Application	
[3402]	PCD 2 Write For Application	
[3403]	PCD 3 Write For Application	
[3404]	PCD 4 Write For Application	
[3405]	PCD 5 Write For Application	
[3406]	PCD 6 Write For Application	
[3407]	PCD 7 Write For Application	

12-21 Process Data Config Write		
Option:	Function:	
[3408]	PCD 8 Write For Application	
[3409]	PCD 9 Write For Application	
[3410]	PCD 10 Write For Application	

12-22 Process Data Config Read		
Option:	Function:	
[0] *	None	
[2]	Motor Speed Unit	
[413]	Motor Speed High Limit [RPM]	
[1500]	Operating hours	
[1501]	Running Hours	
[1502]	kWh Counter	
[1600]	Control Word	
[1601]	Reference [Unit]	
[1602]	Reference [%]	
[1603]	Status Word	
[1605]	Main Actual Value [%]	
[1609]	Custom Readout	
[1610]	Power [kW]	
[1611]	Power [hp]	
[1612]	Motor Voltage	
[1613]	Frequency	
[1614]	Motor current	
[1615]	Frequency [%]	
[1616]	Torque [Nm]	
[1618]	Motor Thermal	
[1620]	Motor Angle	
[1622]	Torque [%]	
[1630]	DC Link Voltage	
[1633]	Brake Energy /2 min	
[1634]	Heatsink Temp.	
[1635]	Inverter Thermal	
[1638]	SL Controller State	
[1639]	Control Card Temp.	
[1650]	External Reference	
[1652]	Feedback[Unit]	
[1653]	Digi Pot Reference	
[1657]	Feedback [RPM]	
[1660]	Digital Input	
[1661]	Terminal 53 Setting	
[1662]	Analog input 53	
[1663]	Terminal 54 Setting	
[1664]	Analog input 54	
[1665]	Analog output 42 [mA]	
[1667]	Pulse input 29 [Hz]	
[1668]	Pulse Input 33 [Hz]	
[1669]	Pulse Output 27 [Hz]	
[1671]	Relay output	
[1672]	Counter A	
[1673]	Counter B	
[1674]	Prec. Stop Counter	
[1684]	Comm. Option STW	

**12-22 Process Data Config Read**

Option:	Function:
[1685]	FC Port CTW 1
[1690]	Alarm Word
[1691]	Alarm Word 2
[1692]	Warning Word
[1693]	Warning Word 2
[1694]	Ext. Status Word
[1695]	Ext. Status Word 2
[1697]	Alarm Word 3
[3421]	PCD 1 Read For Application
[3422]	PCD 2 Read For Application
[3423]	PCD 3 Read For Application
[3424]	PCD 4 Read For Application
[3425]	PCD 5 Read For Application
[3426]	PCD 6 Read For Application
[3427]	PCD 7 Read For Application
[3428]	PCD 8 Read For Application
[3429]	PCD 9 Read For Application
[3430]	PCD 10 Read For Application
[3450]	Actual Position
[3456]	Track Error

**12-28 Store Data Values**

Option:	Function:
[0] *	Off The store function is inactive.
[2]	Store all setups All parameter values in all set-ups are stored in the non-volatile memory.

**12-29 Store Always**

Option:	Function:
[0] *	Off Deactivate the function which always stores received parameter data in non-volatile memory (EEPROM).
[1]	On Activate the function which always stores received parameter data in non-volatile memory (EEPROM).

5.2.4 12-3\* EtherNet/IP

**12-30 Warning Parameter**

Range:	Function:																																		
0* [0 - 65535]	Read-only. Show the EtherNet/IP specific 16-bit status word.																																		
	<table border="1"> <thead> <tr> <th>Bit</th> <th>Description</th> </tr> </thead> <tbody> <tr><td>0</td><td>Owned</td></tr> <tr><td>1</td><td>Not used</td></tr> <tr><td>2</td><td>Configured</td></tr> <tr><td>3</td><td>Not used</td></tr> <tr><td>4</td><td>Not used</td></tr> <tr><td>5</td><td>Not used</td></tr> <tr><td>6</td><td>Not used</td></tr> <tr><td>7</td><td>Not used</td></tr> <tr><td>8</td><td>Minor recoverable fault</td></tr> <tr><td>9</td><td>Minor unrecoverable fault</td></tr> <tr><td>10</td><td>Major recoverable fault</td></tr> <tr><td>11</td><td>Major unrecoverable fault</td></tr> <tr><td>12</td><td>Not used</td></tr> <tr><td>13</td><td>Not used</td></tr> <tr><td>14</td><td>Not used</td></tr> <tr><td>15</td><td>Not used</td></tr> </tbody> </table>	Bit	Description	0	Owned	1	Not used	2	Configured	3	Not used	4	Not used	5	Not used	6	Not used	7	Not used	8	Minor recoverable fault	9	Minor unrecoverable fault	10	Major recoverable fault	11	Major unrecoverable fault	12	Not used	13	Not used	14	Not used	15	Not used
Bit	Description																																		
0	Owned																																		
1	Not used																																		
2	Configured																																		
3	Not used																																		
4	Not used																																		
5	Not used																																		
6	Not used																																		
7	Not used																																		
8	Minor recoverable fault																																		
9	Minor unrecoverable fault																																		
10	Major recoverable fault																																		
11	Major unrecoverable fault																																		
12	Not used																																		
13	Not used																																		
14	Not used																																		
15	Not used																																		
	Table 5.1 Bit Description																																		

**12-31 Net Reference**

Show the reference source in Instance 21/71.

Option:	Function:
[0] *	Off Reference from the network is not active.
[1]	On Reference from the network is active.

**12-32 Net Control**

Show the control source in Instance 21/71.

Option:	Function:
[0] *	Off Control via the network is not active.
[1]	On Control via the network is active.

**12-33 CIP Revision**

Range:	Function:
Size related* [0 - 65535]	Show the CIP revision of the option software.

**12-34 CIP Product Code**

Range:	Function:
Size related* [0 - 65535]	Show the CIP product code.

**12-35 EDS Parameter**

Range:	Function:
0* [0 - 0]	Configure the frequency converter via device net and build the EDS-file.

12-37 COS Inhibit Timer		
Range:	Function:	
0* [0 - 65535]	Change-of-state inhibit timer. If the option is configured for COS operation, this inhibit timer can be configured in the forward open telegram to prevent that continuously changing PCD data generat extensive network traffic. The inhibit time is in milliseconds, 0 = disabled.	

12-38 COS Filter		
Range:	Function:	
0* [0 - 65535]	Change-of-state PCD filters. Set up a filter mask for each word of process data when operating in COS-mode. Single bit in the PCD's can be filtered in/out.	

### 5.2.5 12-8\* Other Ethernet Services

12-80 FTP Server		
Option:	Function:	
[0] *	Disabled	Disable the built-in FTP server.
[1]	Enabled	Enable the built-in FTP server.

12-81 HTTP Server		
Option:	Function:	
[0] *	Disabled	Disable the built-in HTTP (web) server.
[1]	Enabled	Enable the built-in HTTP (web) server.

12-82 SMTP Service		
Option:	Function:	
[0] *	Disabled	Disable the SMTP (e-mail) service on the option.
[1]	Enabled	Enable the SMTP (e-mail) service on the option.

12-83 SNMP Agent		
Option:	Function:	
[0]	Disabled	Disable the local SNMP agent.
[1] *	Enabled	Enable the local SNMP agent.

12-84 Address Conflict Detection		
Option:	Function:	
[0]	Disabled	Disable the function which detects and resolves IP address conflicts with this device in the network.
[1] *	Enabled	Enable the function which detects and resolves IP address conflicts with this device in the network.

12-89 Transparent Socket Channel Port		
Range:	Function:	
4000* [0 - 65535]	Configure the TCP port number for the transparent socket channel. This configuration enables FC telegrams to be sent transparently on Ethernet via TCP. Default	

12-89 Transparent Socket Channel Port		
Range:	Function:	
	value is 4000, 0 means disabled. The uses this port.	

### 5.2.6 12-9\* Advanced Ethernet Settings

12-90 Cable Diagnostic		
Option:	Function:	
	<b>NOTICE</b> The cable diagnostics function is only issued on ports where there is no link (see <i>parameter 12-10 Link Status, Link Status</i> ).	
	Enable/disable advanced cable diagnosis function. If enabled, the distance to cable errors can be read out in <i>parameter 12-93 Cable Error Length</i> . The parameter resumes to the default setting of disable after the diagnostics have finished.	
[0] *	Disabled	Disable the cable diagnostic function.
[1]	Enabled	Enable the cable diagnostic function.

12-91 Auto Cross Over		
Option:	Function:	
[0]	Disabled	Disable the auto-crossover function.
[1] *	Enabled	Enable the auto-crossover function.

12-92 IGMP Snooping		
Option:	Function:	
	This prevents flooding of the Ethernet protocol stack by only forwarding multicast packets to ports that are member of the multicast group. In PROFINET, this function is disabled.	
[0]	Disabled	Disable the IGMP snooping function.
[1] *	Enabled	Enable the IGMP snooping function.

12-93 Cable Error Length		
Range:	Function:	
0* [0 - 65535]	If cable diagnostics is enabled in <i>parameter 12-90 Cable Diagnostic</i> , the built-in switch is possible via time domain reflectometry (TDR). This measurement technique detects common cabling problems such as open circuits, short circuits, and impedance mismatches or breaks in transmission cables. The distance from the option to the error is shown in meters with an accuracy of ±2 m (6.56 ft). The value 0 means that no errors are detected.	

12-94 Broadcast Storm Protection		
Range:	Function:	
-1 % *	[-1 - 20 %]	The built-in switch is capable of protecting the switch system from receiving too many broadcast packages, which can use up network resources. The value indicates the percentage of the total bandwidth that is allowed for broadcast messages.  Example: OFF means that the filter is disabled: All broadcast messages pass through. The value 0% means that no broadcast messages pass through. A value of 10% means that 10% of the total bandwidth is allowed for broadcast messages. If the number of broadcast messages increases above the 10% threshold, they are blocked.

12-95 Inactivity timeout		
Range:	Function:	
120*	[0 - 3600]	

12-96 Port Config		
Enable/disable port-mirroring function. For troubleshooting with a network analyzer tool.		
Option:	Function:	
[0]	Normal	No port-mirroring.
[1]	Mirror Port 1 to 2	All network traffic on port 1 is mirrored to port 2.
[2]	Mirror Port 2 to 1	All network traffic on port 2 is mirrored to port 1.
[10]	Port 1 disabled	
[11]	Port 2 disabled	
[254]	Mirror Int. Port to 1	
[255]	Mirror Int. Port to 2	

12-98 Interface Counters		
Range:	Function:	
4000*	[0 - 4294967295]	Read-only. Advanced interface counters from the built-in switch can be used for low-level troubleshooting. The parameter shows a sum of port 1+port 2.

12-99 Media Counters		
Range:	Function:	
0*	[0 - 4294967295]	Read-only. Advanced interface counters from the built-in switch can be used for low-level troubleshooting. The parameter shows a sum of port 1+port 2.



### 5.3 Parameter List

#### 5.3.1 Introduction

##### Changes during operation

True means that the parameter can be changed while the frequency converter is in operation. False means that the frequency converter must be stopped before a change can be made.

##### 4 set-up

All set-ups: The parameter can be set individually in each of the 4 set-ups, for example, 1 single parameter can have 4 different data values.

1 set-up: The data value is same in all set-ups.

Data type	Description	Type
2	Integer 8	Int8
3	Integer 16	Int16
4	Integer 32	Int32
5	Unsigned 8	UInt8
6	Unsigned 16	UInt16
7	Unsigned 32	UInt32
9	Visible string	VisStr
33	Normalized value 2 bytes	N2
35	Bit sequence of 16 boolean variables	V2
54	Time difference w/o date	TimD

Table 5.2 Data Type

#### 5.3.2 Parameter List

Parameter	Default value	4 set-up	Change during operation	Conversion index	Type
Parameter 8-01 Control Site	[0] Dig. & ctrl. word	All set-ups	TRUE	-	UInt8
Parameter 8-02 Control Source	-	All set-ups	TRUE	-	UInt8
Parameter 8-03 Control Timeout Time	1	1 set-up	TRUE	-1	UInt16
Parameter 8-04 Control Timeout Function	[0] Off	1 set-up	TRUE	-	UInt8
Parameter 8-07 Diagnosis Trigger	[0] Disable	1 set-up	TRUE	-	UInt8
Parameter 8-10 Control Word Profile	[0] FC profile	All set-ups	TRUE	-	UInt8
Parameter 8-14 Configurable Control Word CTW	[1] Profile default	All set-ups	TRUE	-	UInt8
Parameter 8-19 Product Code	-	1 set-up	TRUE	0	UInt32
Parameter 8-30 Protocol	[0] FC	1 set-up	TRUE	-	UInt8
Parameter 8-31 Address	1	1 set-up	TRUE	0	UInt8
Parameter 8-32 Baud Rate	[2] 9600 Baud	1 set-up	TRUE	-	UInt8
Parameter 8-33 Parity / Stop Bits	[0] Even Parity, 1 Stop Bit	1 set-up	TRUE	-	UInt8
Parameter 8-35 Minimum Response Delay	0.010	1 set-up	TRUE	-3	UInt16
Parameter 8-36 Maximum Response Delay	-	1 set-up	TRUE	-3	UInt16
Parameter 8-37 Maximum Inter-char delay	0.025 s	1 set-up	TRUE	-3	UInt16
Parameter 8-42 PCD Write Configuration	[0] None	2 set-ups	TRUE	-	UInt8
Parameter 8-43 PCD Read Configuration	[0] None	1 set-up	TRUE	-	UInt8
Parameter 8-50 Coasting Select	[3] Logic OR	All set-ups	TRUE	-	UInt8
Parameter 8-51 Quick Stop Select	[3] Logic OR	All set-ups	TRUE	-	UInt8
Parameter 8-52 DC Brake Select	[3] Logic OR	All set-ups	TRUE	-	UInt8
Parameter 8-53 Start Select	[3] Logic OR	All set-ups	TRUE	-	UInt8
Parameter 8-54 Reversing Select	[3] Logic OR	All set-ups	TRUE	-	UInt8
Parameter 8-55 Set-up Select	[3] Logic OR	All set-ups	TRUE	-	UInt8
Parameter 8-56 Preset Reference Select	[3] Logic OR	All set-ups	TRUE	-	UInt8
Parameter 8-57 Profdrive OFF2 Select	[3] Logic OR	All set-ups	TRUE	-	UInt8

Parameter	Default value	4 set-up	Change during operation	Conversion index	Type
Parameter 8-58 Profdrive OFF3 Select	[3] Logic OR	All set-ups	TRUE	-	Uint8
Parameter 8-79 Protocol Firmware version	-	1 set-up	FALSE	-2	Uint16
Parameter 8-80 Bus Message Count	0	1 set-up	TRUE	0	Uint32
Parameter 8-81 Bus Error Count	0	1 set-up	TRUE	0	Uint32
Parameter 8-82 Slave Messages Rcvd	0	1 set-up	TRUE	0	Uint32
Parameter 8-83 Slave Error Count	0	1 set-up	TRUE	0	Uint32
Parameter 8-84 Slave Messages Sent	0	1 set-up	TRUE	0	Uint32
Parameter 8-85 Slave Timeout Errors	0	1 set-up	TRUE	0	Uint32
Parameter 8-88 Reset FC port Diagnostics	[0] Do not reset	1 set-up	TRUE	-	Uint8
Parameter 8-90 Bus Jog 1 Speed	100 RPM	All set-ups	TRUE	0	Uint16
Parameter 8-91 Bus Jog 2 Speed	200 RPM	All set-ups	TRUE	0	Uint16
Parameter 12-00 IP Address Assignment	[10] DCP	1 set-up	TRUE	-	Uint8
Parameter 12-01 IP Address	0	1 set-up	TRUE	-	Oct. string 4
Parameter 12-02 Subnet Mask	0	1 set-up	TRUE	-	Oct. string 4
Parameter 12-03 Default Gateway	0	1 set-up	TRUE	-	Oct. string 4
Parameter 12-04 DHCP Server	0	1 set-up	TRUE	-	Oct. string 4
Parameter 12-05 Lease Expires	-	All set-ups	TRUE	-	Time diff. w/date
Parameter 12-06 Name Servers	0	1 set-up	TRUE	-	Oct. string 4
Parameter 12-07 Domain Name	0	1 set-up	TRUE	-	Visible string 48
Parameter 12-08 Host Name	0	1 set-up	TRUE	-	Visible string 48
Parameter 12-09 Physical Address	0	1 set-up	TRUE	-	Visible string 17
Parameter 12-10 Link Status	[0] No Link	All set-ups	TRUE	-	Uint8
Parameter 12-11 Link Duration	-	All set-ups	TRUE	-	Time diff. w/date
Parameter 12-12 Auto Negotiation	[1] On	1 set-up	TRUE	-	Uint8
Parameter 12-13 Link Speed	[0] None	1 set-up	TRUE	-	Uint8
Parameter 12-14 Link Duplex	[1] Full Duplex	1 set-up	TRUE	-	Uint8
Parameter 12-18 Supervisor MAC	0	2 set-ups	TRUE	0	Oct. string 6
Parameter 12-19 Supervisor IP Addr.	0	2 set-ups	TRUE	0	Oct. string 4
Parameter 12-20 Control Instance	-	1 set-up	TRUE	-	Uint8
Parameter 12-21 Process Data Config Write	[0] None	All set-ups	TRUE	-	Uint16
Parameter 12-22 Process Data Config Read	[0] None	All set-ups	TRUE	-	Uint16
Parameter 12-28 Store Data Values	[0] Off	All set-ups	TRUE	-	Uint8
Parameter 12-29 Store Always	[0] Off	1 set-up	TRUE	-	Uint8
Parameter 12-30 Warning Parameter	0	All set-ups	TRUE	0	Uint16
Parameter 12-31 Net Reference	[0] Off	All set-ups	TRUE	-	Uint8
Parameter 12-32 Net Control	[0] Off	All set-ups	TRUE	-	Uint8
Parameter 12-33 CIP Revision	-	All set-ups	TRUE	-	Uint16
Parameter 12-34 CIP Product Code	-	1 set-up	TRUE	-	Uint16
Parameter 12-35 EDS Parameter	0	All set-ups	TRUE	0	Uint32
Parameter 12-37 COS Inhibit Timer	0	All set-ups	TRUE	0	Uint16
Parameter 12-38 COS Filter	0	All set-ups	TRUE	0	Uint16
Parameter 12-80 FTP Server	[0] Disabled	1 set-up	TRUE	-	Uint8
Parameter 12-81 HTTP Server	[0] Disabled	1 set-up	TRUE	-	Uint8
Parameter 12-82 SMTP Service	[0] Disabled	1 set-up	TRUE	-	Uint8

Parameter	Default value	4 set-up	Change during operation	Conversion index	Type
Parameter 12-83 SNMP Agent	[1] Enabled	2 set-ups	TRUE	-	Uint8
Parameter 12-84 Address Conflict Detection	[1] Enabled	2 set-ups	TRUE	-	Uint8
Parameter 12-89 Transparent Socket Channel Port	-	1 set-up	TRUE	0	Uint16
Parameter 12-90 Cable Diagnostic	[0] Disabled	1 set-up	TRUE	-	Uint8
Parameter 12-91 Auto Cross Over	[1] Enabled	1 set-up	TRUE	-	Uint8
Parameter 12-92 IGMP Snooping	[1] Enabled	1 set-up	TRUE	-	Uint8
Parameter 12-93 Cable Error Length	0	1 set-up	TRUE	0	Uint16
Parameter 12-94 Broadcast Storm Protection	-1%	1 set-up	TRUE	0	Int8
Parameter 12-95 Broadcast Storm Filter	[0] Broadcast only	1 set-up	TRUE	-	Uint8
Parameter 12-96 Port Config	-	1 set-up	TRUE	-	Uint8
Parameter 12-98 Interface Counters	4000	All set-ups	TRUE	0	Uint32
Parameter 12-99 Media Counters	0	All set-ups	TRUE	0	Uint32

Table 5.3 Parameter List

### 5.3.3 Conversion

The various attributes of each parameter are shown in factory setting. Parameter values are transferred as whole numbers only. Conversion factors are therefore used to transfer decimals.

A conversion factor of 0.1 means that the value transferred is multiplied by 0.1. The value 100 is therefore read as 10.0.

Examples:

- 0 s ⇒ conversion index 0
- 0.00 s ⇒ conversion index -2
- 0 ms ⇒ conversion index -3
- 0.00 ms ⇒ conversion index -5

Conversion index	Conversion factor
100	1
75	3600000
74	3600
70	60
67	1/60
6	1000000
5	100000
4	10000
3	1000
2	100
1	10
0	1
-1	0.1
-2	0.01
-3	0.001
-4	0.0001
-5	0.00001
-6	0.000001

Table 5.4 Conversion Table

## 6 Troubleshooting

### 6.1 Step-by-step Troubleshooting

#### 6.1.1 LED Status

The EtherNet/IP interface has 3 bicolored LEDs that allow fast and detailed diagnosis. Each LED is linked to its unique part of the EtherNet/IP interface, see *Table 6.1*.

LED label	Description
MS	Module status. Reflects the activity on the EtherNet/IP stack.
NS1	Network status 1. Reflects the activity on Ethernet port 1.
NS2	Network status 2. Reflects the activity on Ethernet port 2.

Table 6.1 LED Label

6

State	LED		Description
Standby	Green:	Flashing green	The device needs commissioning.
Device operational	Green:	Solid green	The device is operational.
Major recoverable fault	Red:	Flashing red	The device has detected a recoverable fault (MAR).
Major unrecoverable fault	Red:	Solid red	The device has detected an unrecoverable fault (MAU).
Self-test	Red:	Flashing red/ green	The EIP option is in self-test mode.
	Green:		

Table 6.2 MS: Module Status

State	LED		Description
No connections	Green:	Flashing green	There are no established CIP connections to the device.
Connected	Green:	Solid green	There is at least 1 established CIP connection to the device.
Connection timeout	Red:	Flashing red	1 or more CIP connections have timed out.
Duplicate IP	Red:	Solid red	The IP address assigned to the device is already in use.
Self-test	Red:	Flashing red/ green	The EIP option is in self-test mode.
	Green:		

Table 6.3 NS1+NS2: Network Status (1 per Port)

#### 6.1.2 No Communication with the Frequency Converter

##### Check: Link status

If CIP connection is not established, the status of the Ethernet link cannot be directly identified using the LEDs. Verify presence of the link via *parameter 12-10 Link Status*. Verify that the link is constantly present via *parameter 12-11 Link Duration*. The parameter shows the duration of the present link and is preset to 00:00:00:00 when the link is broken.

##### Check: Cabling

In rare cases of cabling misconfiguration, the option may show the presence of a link, but no communication is running. Exchange the cable if in doubt.

##### Check: IP address

Verify that the option has a valid IP address (refer to *parameter 12-01 IP Address*). When the option has identified a duplicate IP address, NS LEDs are solid red. When the option is set up for BOOTP or DHCP, verify that a BOOTP or DHCP server is connected in *parameter 12-04 DHCP Server*. If no server is connected, the parameter shows: 000.000.000.000.

## 6.2 Warnings and Alarms

### **NOTICE**

Refer to the *operating guide* for the frequency converter for an overview of warning and alarm types, and for the full list of warnings and alarms.

Alarm word and warning word are shown on the frequency converter display in hex format. When there is more than 1 warning or alarm, the sum of all warnings or alarms is shown. Alarm word and warning word can also be shown using the fieldbus in *parameter 16-90 Alarm Word* and *parameter 16-92 Warning Word*.

Bit (hex)	Unit diagnoses bit	Alarm word ( <i>parameter 16-90 Alarm Word</i> )	Alarm number
00000001	48	Brake check	28
00000002	49	Power card overtemperature	69
00000004	50	Ground fault	14
00000008	51	Control card overtemperature	65
00000010	52	Control word timeout	18
00000020	53	Overcurrent	13
00000040	54	Torque limit	12
00000080	55	Motor thermistor overtemperature	11
00000100	40	Motor ETR overtemperature	10
00000200	41	Inverter overloaded	9
00000400	42	DC-link undervoltage	8
00000800	43	DC-link overvoltage	7
00001000	44	Short circuit	16
00004000	46	Mains phase loss	4
00008000	47	AMA not OK	52
00010000	32	Live zero error	2
00020000	33	Internal fault	38
00040000	34	Brake overload	26
00080000	35	Motor phase U is missing	30
00100000	36	Motor phase V is missing	31
00200000	37	Motor phase W is missing	32
00400000	38	Fieldbus comm. fault	34
00800000	39	24 V supply fault	47
01000000	24	Mains failure	36
04000000	26	Brake resistor short circuit	25
08000000	27	Brake chopper fault	27
10000000	28	Option change	67
20000000	29	Frequency converter initialization	80
40000000	30	Safe Torque Off	68
80000000	31	Mechanical brake low	63

**Table 6.4 Parameter 16-90 Alarm Word**

Bit (hex)	Unit diagnoses bit	Warning word ( <i>parameter 16-92 Warning Word</i> )	Alarm number
00000001	112	Brake check	28
00000002	113	Power card overtemperature	69
00000004	114	Ground fault	14
00000008	115	Control card overtemperature	65
00000010	116	Control word timeout	18
00000020	117	Overcurrent	13
00000040	118	Torque limit	12
00000080	119	Motor thermistor overtemperature	11
00000100	104	Motor ETR overtemperature	10
00000200	105	Inverter overloaded	9
00000400	106	DC-link undervoltage	8
00000800	107	DC-link overvoltage	7
00004000	110	Mains phase loss	4
00008000	111	No motor	3
00010000	96	Live zero error	2
00040000	98	Brake overload	26
00080000	99	Brake resistor short circuit	25
00100000	100	Brake chopper fault	27
00400000	102	Fieldbus comm. fault	34
00800000	103	24 V supply fault	47
01000000	88	Mains failure	36
02000000	89	Current limit	59
10000000	92	Encoder loss	61
40000000	94	Safe Torque Off	68

**Table 6.5 Parameter 16-92 Warning Word**

Bit	hex	Dec	Extended status word (parameter 16-94 Ext. Status Word)
0	00000001	1	Ramping
1	00000002	2	AMA running
2	00000004	4	Start CW/CCW
3	00000008	8	Slow down
4	00000010	16	Catch up
5	00000020	32	Feedback high
6	00000040	64	Feedback low
7	00000080	128	Output current high
8	00000100	256	Output current low
9	00000200	512	Output frequency high
10	00000400	1024	Output frequency low
11	00000800	2048	Brake check OK
12	00001000	4096	Braking max
13	00002000	8192	Braking
14	00004000	16384	Reserved
15	00008000	32768	OVC active
16	00010000	65536	AC brake
17	00020000	131072	Reserved
18	00040000	262144	Reserved
19	00080000	524288	Reference high
20	00100000	1048576	Reference low
21	00200000	2097152	Reserved
22	00400000	4194304	Reserved
23	00800000	8388608	Reserved
24	01000000	16777216	Reserved
25	02000000	33554432	Reserved
26	04000000	67108864	Reserved
27	08000000	134217728	Reserved
28	10000000	268435456	Reserved
29	20000000	536870912	Reserved
30	40000000	1073741824	Reserved
31	80000000	2147483648	Database busy

**Table 6.6 Extended Status Word**

Bit (hex)	Communication option STW (parameter 16-84 Comm. Option STW)
00000001	Parameterization OK.
00000002	Configuration OK.
00000004	Clear mode active.
00000008	Baud rate search.
00000010	Waiting for parameterization.
00000020	Waiting for configuration.
00000040	In data exchange.
00000080	Not used.
00000100	Not used.
00000200	Not used.
00000400	Not used.
00000800	MCL2/1 connected.
00001000	MCL2/2 connected.
00002000	MCL2/3 connected.
00004000	Data transport active.
00008000	Unused.

**Table 6.7 Parameter 16-84 Comm. Option STW**
**NOTICE**

*Parameter 16-84 Comm. Option STW is not part of extended diagnosis.*

For diagnosis, read out the alarm words, warning words, and extended status words via fieldbus or optional fieldbus.

## 7 Appendix

### 7.1 Supported CIP Objects

As in all implementations of CIP, EtherNet/IP shares the common object model. Objects are a common method to describe the specific application implemented in a device.

Data is structured in classes, instances, and attributes:

A class is a group of objects with the same structure. These groups of objects within a class are called instances. Every instance provides the same data elements called attributes. Each class provides services to access data or to change the state of an object.

Attribute	Access	Name	Data type	Description
1	Get	Vendor	Uint (97)	Danfoss Drives vendor code
2	Get	Device type	Uint (2)	AC Drive
3	Get	Product code	Uint	Value of <i>parameter 12-34 CIP Product Code</i>
4	Get	Revision	Struct	Value of <i>parameter 12-33 CIP Revision</i>
5	Get	Status	WORD	EIP status word ( <i>parameter 12-30 Warning Parameter</i> )
6	Get	Serial number	UDINT	Serial number
7	Get	Product name	String	Value of <i>parameter 15-40 FC Type</i>
8	Get	State	Uint	0 = Non-existing 1 = Device self-testing 2 = Standby 3 = Operational 4 = Major recoverable fault 5 = Major unrecoverable fault 6–254 = Reserved 255 = Default for get attribute all
9	Get	Conf. consistency value	Uint	–



Table 7.1 Instance Attributes-Class ID 0x01 Identity Object

Instance	Access	Name	Size	Description
20	Set	ODVA basic speed control output	2 words	–
21	Set	ODVA extended speed control output	2 words	–
70	Get	ODVA basic speed control input	2 words	–
71	Get	ODVA extended speed control input	2 words	–
100	Set	Danfoss basic control output	2 words	–
101	Set	Danfoss extended control output	4 words	–
103	Set	Danfoss extended control output	10 words	–
150	Get	Danfoss basic control input	2 words	–
151	Get	Danfoss extended control input	4 words	–
153	Get	Danfoss extended control input	10 words	–

Table 7.2 Instance Attributes-Class ID 0x04 Assembly Objects

Attribute	Access	Name	Data type	Description
1	Get	Open requests	Uint	Number of forward open requests received.
2	Get	Open format rejects	Uint	Number of forward open requests rejected due to bad format.
3	Get	Open resource rejects	Uint	Number of forward open requests rejected due to lack of resources.
4	Get	Open other rejects	Uint	Number of forward open requests rejected due to other reasons.
5	Get	Close requests	Uint	Number of forward close requests received.
6	Get	Close format requests	Uint	Number of forward close requests rejected due to bad format.
7	Get	Close other requests	Uint	Number of forward close requests rejected due to other reasons.
8	Get	Connection timeouts	Uint	Number of connection timeouts.
9	Get	Connection entry list struct of NumConnEntries	INT	Number of connection entries ConnOpenBits ARRAY of BOOL List of connection data.

Table 7.3 Instance Attributes-Class ID 0x06 Connection Manager

Attribute	Access	Name	Data type	Parameter	Description
1	Get	Number of attributes supported	USINT	-	7
2	Get	List of attributes supported	Array of USINT	-	3,6,7,8,9,12,15
3	Get/Set	Motor type	USINT	1-10	3: PM sync. motor ( only) 7: Squirrel cage induction motor
6	Get/Set	Rated current	Uint	1-24	Unit: 100 mA
7	Get/Set	Rated voltage	Uint	1-22	Unit: Volt
8	Get/Set	Rated power	UDINT	1-20	Unit: Watt
9	Get/Set	Rated frequency	Uint	1-23	Unit: Hertz
12	Get/Set	Pole count	Uint	1-39	Number of poles in motor
15	Get/Set	Base speed	Uint	1-25	Unit: RPM

Table 7.4 Instance Attributes-Class ID 0x28 Motor Data Object

**NOTICE**

Class ID 0x28 is only available when ODVA profile is selected in *parameter 8-10 Control Word Profile*.

Attribute	Access	Name	Data type	Description
1	Get	Number of attributes supported	USINT	12
2	Get	List of supported attributes	Array of USINT	3,4,4,5,6,7,8,9,10,11,12,13,15
3	Get/Set	Run 1 (forward)	Boolean	Frequency converter CTW bit 6=Run 1 XOR Run 2 Frequency converter CTW bit 15 = 0.
4	Get/Set	Run 2 (reverse)	Boolean	Frequency converter CTW bit 6 = Run 1 XOR Run 2 Frequency converter CTW bit 15 = 1.
5	Get/Set	Network control	Boolean	<i>Parameter 12-32 Net Control</i> value written from option.
6	Get	State	USINT	The state of the CIP state-machine.
7	Get	Running 1	Boolean	Run 1 AND bit 11 in frequency converter STW
8	Get	Running 2	Boolean	Run 2 AND bit 11 in frequency converter STW.
9	Get	Ready	Boolean	STATE_ENABLED or STATE_STOPPING or STATE_FAULT_STOP from state-machine.
10	Get	Faulted	Boolean	Bit 3 in frequency converter STW.
11	Get	Warning	Boolean	Bit 7 in frequency converter STW.
12	Get/Set	Fault reset	Boolean	Bit 7 in frequency converter CTW.



Attribute	Access	Name	Data type	Description
13	Get	Fault code	Uint	Mapping of <i>parameter 16-90 Alarm Word</i> to CIP-specific fault codes.
15	Get	Control from net	Boolean	<i>Parameter 12-31 Net Reference</i> value written from option.

Table 7.5 Instance Attributes-Class ID 0x29 Control Supervisor Object

CIP malfunction code	Meaning	Frequency converter code alarm word	CIP malfunction meaning	CIP classification
0	No alarm	0000 0000	No fault	-
0	Unused	0000 0001	No fault	-
4210	Frequency converter overtemperature	0000 0002	Excessive device temperature	MAR
2240	Ground fault	0000 0004	Short to ground	MAU
0	Unused	0000 0008	No fault	-
8100	Control word timeout	0000 0010	Communication	MIR
2310	Overcurrent	0000 0020	Continuous overcurrent	MAU
8302	Torque limit	0000 0040	Torque limiting	MAR
4310	Motor thermistor	0000 0080	Excess frequency converter temperature	MAR
4310	Motor ETR overtemperature	0000 0100	Excess frequency converter temperature	MAR
2311	Inverter overloaded	0000 0200	Current inside the device, No. 1	MAR
3220	DC-link undervoltage	0000 0400	Undervoltage inside the device	MAR
3210	DC-link overvoltage	0000 0800	Overvoltage inside the device	MAR
2130	Short circuiting	0000 1000	Short circuit	MAU
2213	Inrush fault	0000 2000	Overcurr.marduring start-up	
3130	Mains phase loss	0000 4000	Phase failure	MAU
5210	AMT fail	0000 8000	Measurement circuit	MIR
1000	Live zero fault	0001 0000	General fault	MAR
6100	Internal fault	0002 0000	Internal software fault	MAU
7110	Brake resistor power limit	0004 0000	Brake chopper	MAU
3300	Motor phase U missing	0008 0000	Output voltage	MAU
3300	Motor phase V missing	0010 0000	Output voltage	MAU
3300	Motor phase W missing	0020 0000	Output voltage	MAU
8100	Fieldbus fault	0040 0000	Communication	MIR
5112	24 V supply fault	0080 0000	+24 V power supply	MAU
3100	Mains failure	0100 0000	Mains voltage	MAR
5110	1.8 V supply fault	0200 0000	Low voltage power supply	MAU
7110	Brake resist. short circ.	0400 0000	Brake chopper	MAR
7110	Brake chopper fault	0800 0000	Brake chopper	MAR
0	Unused	1000 0000	No fault	-
0	Unused	2000 0000	No fault	-
0	Unused	4000 0000	No fault	-
0	Unused	8000 0000	No fault	-

Table 7.6 Attribute 13 Fault Code

Service code	Service name	Service description
0Eh	Get_attribute_single	Returns contents of specified attribute.
10h	Set_attribute_single	Sets the contents of specified attribute.
05h	Reset	Resets frequency converter to its start-up state.

Table 7.7 Services Supported

**NOTICE**

Class ID 0x29 is only available when ODVA profile is selected in *parameter 8-10 Control Word Profile*.

Attribute	Access rule	Information	Data type	Content
1	Get	Number of attributes supported	USINT	12.
2	Get	List of attributes supported	USINT	3,4,6,7,8,18,19,20,21,22,28,29.
3	Get	At reference	Boolean	Bit 8 of frequency converter STW.
4	Get/Set	Network reference	Boolean	Value written to <i>parameter 10-14 Net Reference</i> .
6	Get/Set	Drive mode	USINT	Mapping of values from <i>parameter 1-00 Configuration Mode</i> .
7	Get	Actual speed	INT	See attribute 22.
8	Get/Set	Reference speed	INT	See attribute 22.
18	Get/Set	Acceleration time	Uint	Scaled with attribute 28 and written to <i>parameter 3-41 Ramp 1 Ramp Up Time</i> .
19	Get/Set	Deceleration time	Uint	Scaled with attribute 28 and written to <i>parameter 3-42 Ramp 1 Ramp Down Time</i> .
20	Get/Set	Low speed limit	Uint	Scaled with attribute 22 and written to <i>parameter 4-11 Motor Speed Low Limit [RPM]</i> .
21	Get/Set	High speed limit	Uint	Scaled with attribute 22 and written to <i>parameter 4-13 Motor Speed High Limit [RPM]</i> .
22	Get/Set	Speed scale	SINT	Forms the speed reference and main actual value for the frequency converter together with attributes 7 and 8.
28	Get/Set	Time scale	SINT	Scaling factor for all time attributes.
29	Get	Ref from net	Boolean	Value of <i>parameter 10-14 Net Reference</i> .

Table 7.8 Instance Attributes-Class ID 0x2A AC/DC Drive Object

Value of attribute 6	ODVA text	Value of <i>parameter 1-00 Configuration Mode</i>	Frequency converter text
0	Vendor specific	Remaining values not listed below.	NA
1	Open-loop speed ctr.	0	Speed open loop
2	Closed-loop speed ctr.	1	Speed closed loop
3	Torque control	NA	NA
4	Process control	NA	NA
5	Position control	NA	NA

Table 7.9 Attribute 6 Drive Mode

**NOTICE**

Class ID 0x2A is only available when ODVA profile is selected in *parameter 8-10 Control Word Profile*.

Attribute	Access rule	Name	Data type	Description of attribute	Parameter in frequency converter
1	Get	Status	DWORD	Interface status	-
2	Get	Configuration capability	DWORD	Interface capability flags	-
3	Get/Set	Configuration control	DWORD	Interface control flags	-
4	Get	Physical link object	STRUCT of:	Path to physical link object	-
		Path size	Uint	Size of path	-
		Path	Padded EPATH	Logical segments identifying the physical link object	-
5	Get/Set	Interface configuration	STRUCT of:	TCP/IP network interface configuration	-
		IP address	UDINT	The device IP address	12-01
		Network mask	UDINT	The device network mask	12-02
		Gateway address	UDINT	Default gateway address	12-03
		Name server	UDINT	Primary name server	12-06 [0]
		Name server 2	UDINT	Secondary name server	12-06 [1]
6	Get/Set	Host name	STRING	Host name	12-08



Table 7.10 Instance Attributes-Class ID 0xF5 Interface Object

3 instances of the link object are implemented:

- Instances 1 and 2 relate to the physical ports 1 and 2 of the option.
- Instance 3 relates to the internal interface of the option after the built-in switch.

Attribute	Access rule	Name	Data type	Description of attribute	Parameter in frequency converter
1	Get	Interface speed	UDINT	Interface speed in Mbps (that is 0, 10, 100, 1000, and so on).	12-13
2	Get	Interface flags	DWORD	Interface status flags.	-
3	Get	Physical address	ARRAY of 6 USINTs	MAC layer address.	12-09
4	Get	Interface counters	STRUCT of	-	-
		In octets	UDINT	Octets received on the interface.	12-98 [0]
		In Ucast packets	UDINT	Unicast packets received on the interface	12-98 [1]
		In NUCast packets	UDINT	Non-unicast packets received on the interface.	12-98 [2]
		In discards	UDINT	Inbound packets received on the interface but discarded.	12-98 [3]
		In errors	UDINT	Inbound packets that contain errors (does not include <i>In Discards</i> ).	12-98 [4]
		In unknown protos	UDINT	Inbound packets with unknown protocol.	12-98 [5]
		Out octets	UDINT	Octets sent on the interface	12-98 [6]
		Out Ucast packets	UDINT	Unicast packets sent on the interface.	12-98 [7]
		Out NUCast packets	UDINT	Non-unicast packets sent on the interface.	12-98 [8]
		Out discards	UDINT	Outbound packets discarded.	12-98 [9]
		Out errors	UDINT	Outbound packets that contain errors.	12-98 [10]

Attribute	Access rule	Name	Data type	Description of attribute	Parameter in frequency converter
5	Get	Media counters	STRUCT of:	Media-specific counters.	-
		Alignment errors	UDINT	Frames received that are not an integral number of octets in length.	12-99 [0]
		FCS errors	UDINT	Frames received that do not pass the FCS check.	12-99 [1]
		Single collisions	UDINT	Successfully transmitted frames which experienced exactly 1 collision.	12-99 [2]
		Multiple collisions	UDINT	Successfully transmitted frames which experienced more than 1 collision.	12-99 [3]
		SQE test errors	UDINT	Number of times SQE test error message is generated.	12-99 [4]
		Deferred transmissions	UDINT	Frames for which first transmission attempt is delayed because the medium is busy.	12-99 [5]
		Late collisions	UDINT	Number of times a collision is detected later than 512 bit times into the transmission of a packet.	12-99 [6]
		Excessive collisions	UDINT	Frames for which transmission fails due to excessive collisions.	12-99 [7]
		MAC transmit errors	UDINT	Frames for which transmission fails due to an internal MAC sub layer transmit error.	12-99 [8]
		Carrier sense errors	UDINT	Times that the carrier sense condition was lost or never asserted when attempting to transmit a frame.	12-99 [9]
		Frame too long	UDINT	Frames received that exceed the maximum permitted frame size.	12-99 [10]
MAC receive errors	UDINT	Frames for which reception on an interface fails due to an internal MAC sub layer receive error.	12-99 [11]		
6	Set	Interface control	STRUCT of:	Configuration for physical interface.	-
		Control bits	WORD	Interface control bits.	-
		Forced interface speed	Uint	Speed at which the interface shall be forced to operate speed in Mbps (10, 100, 1000, and so on).	-
7	Get	Interface label	SHORT_STRING	Human readable identification.	-
8	Get	Link list size	USINT	Number of members in link list.	-
9	Get	Link list	ARRAY OF uint	Link list between internal and all corresponding external interfaces.	-

Table 7.11 Instance Attributes-Class ID 0xF6 Link Object

Service code	Supported		Service name	Description of service
	Class	Instance		
01h	Yes	Yes	Get_attribute_all	Returns a predefined listing of the objects attributes.
0Eh	Yes	Yes	Get_attribute_single	Returns the contents of the specified attribute.
10h	-	Yes	Set_attribute_single	Modifies a single attribute.
43h	-	Yes	Get_and_clear	Gets, then clears the specified attribute (interface counters or media counters).

Table 7.12 Services Supported

Service code	Supported		Service name	Description of service
	Class	Instance		
0Eh	Yes	Yes	Get_attribute_single	Returns contents of specified attribute.
01h	Yes	Yes	Get_attributes_all	Returns predefined listing of object attributes.
10h	No	Yes	Set_attribute_single	Modifies attribute.
4Bh	No	Yes	Get_Enum_string	Reads enumerated strings from parameter instance.

Table 7.13 Services Supported

The CIP class ID 100–199 (0x64 to 0xC7) gives access to all parameters.

Class (decimal)	Parameter range
100	0-01 to 0-99
101	1-00 to 1-99
102	2-00 to 2-99
103	3-00 to 3-99
104	4-00 to 4-99
105	5-00 to 5-99
106	6-00 to 6-99
107	7-00 to 7-99
108	8-00 to 8-99
109	9-00 to 9-99
110	10-00 to 10-99
111	11-00 to 11-99
...	...
199	99-00 to 99-99

Table 7.14 Class ID 0x64 – 0xC7 Objects

The class instance and attribute act in the following way:

- 100 added to the parameter group = the value for the class.
- 100 added to the remaining parameter number = the value for the instance.

Service code	Supported		Service name	Description of service
	Class	Instance		
0Eh	Yes	Yes	Get_attribute_single	Returns contents of specified attribute.
10h	No	Yes	Set_attribute_single	Modifies attribute.
4Bh	No	Yes	Get_att_scattered	Returns specified parameter values.
4Ch	No	Yes	Set_att_scattered	Sets specified parameter values.

Table 7.15 Services Supported

- 100 added to the array index of the parameter = the value for the attribute.

**Examples (fictitious parameters)**

- Parameter 0-01 [index 0] = class 100, instance 101, attribute 100.
- Parameter 1-00 [index 0] = class 101, instance 100, attribute 100 -Parameter 2-59 [index 0] = class 102, instance 159, attribute 100.
- Parameter 5-34 [index 3] = class 105, instance 134, attribute 103.
- Parameter 6-54 [index 9] = class 106, instance 154, attribute 109.
- Parameter 10-01 [index 0] = class 110, instance 101, attribute 100.

All values in decimal.

All parameters are accessed in the active set-up (parameter 0-10 Active Set-up).

**Index**

**A**

Abbreviation..... 3  
 Additional resources..... 2  
 Alarm word..... 35  
 Alarms..... 35  
 Approval and certification..... 2  
 Approvals..... 2  
 Assembly instances..... 12, 14  
 Assembly object..... 37

**C**

Cabling..... 29, 34  
 Certifications..... 2  
 Change-of-state..... 13  
 CIP object..... 13, 37  
 Class-1 connection..... 13  
 Class-3 connection..... 13  
 Configuration..... 7, 12, 21  
 Configuration capability..... 40  
 Connection name..... 13  
 Control supervisor object..... 39  
 Control word..... 15, 17  
 Control word profile..... 14  
 Convention..... 3

**D**

Data type..... 37, 38, 40  
 Default settings..... 31  
 Discharge time..... 4

**E**

EDS..... 7  
 Ethernet..... 6, 7, 11, 26, 29, 34  
 EtherNet/IP..... 7, 11, 37

**F**

FC MC protocol..... 23  
 FC profile..... 15, 16  
 Forward open..... 13, 37  
 Frequency converter profile..... 12, 19

**G**

General settings..... 21

**H**

High voltage..... 4

**I**

I/O..... 3, 12, 13  
 Identity object..... 37  
 IGMP..... 11  
 Interface object..... 40  
 IP setting..... 6  
 IP traffic..... 11

**L**

Leakage current..... 5  
 LED..... 3  
 Link object..... 40, 41  
 Load sharing..... 4

**M**

Master..... 7  
 Message parameter..... 13  
 Motor data object..... 38  
 Multicast..... 11, 13

**N**

Network..... 11, 14, 30, 40

**O**

Object..... 43  
 Object model..... 37  
 ODVA profile..... 38, 40

**P**

Parameter..... 6, 43  
 Port diagnostics..... 25  
 Port setting..... 22

**Q**

Qualified personnel..... 4

**R**

Redundancy..... 11  
 Reference..... 3, 14, 15, 17, 18, 40

**S**

Safety..... 5  
 Spanning tree..... 3

Status word..... 16, 18

Symbol..... 3

## T

Topology..... 11

## U

Unconnected message..... 13

Unintended start..... 4

## W

Warning word..... 35

Warnings..... 35



.....  
Danfoss can accept no responsibility for possible errors in catalogues, brochures and other printed material. Danfoss reserves the right to alter its products without notice. This also applies to products already on order provided that such alterations can be made without subsequential changes being necessary in specifications already agreed. All trademarks in this material are property of the respective companies. Danfoss and the Danfoss logotype are trademarks of Danfoss A/S. All rights reserved.  
.....

Danfoss A/S  
Ulsnaes 1  
DK-6300 Graasten  
vlt-drives.danfoss.com

